

升 鸿
ShengHong

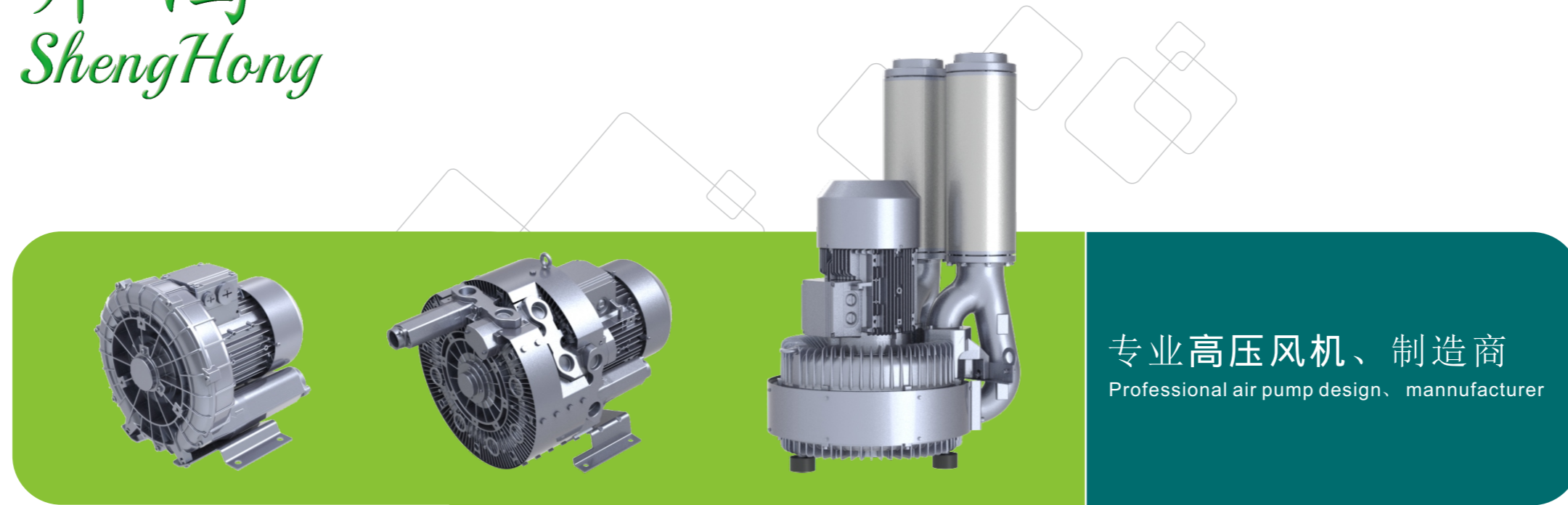

专业高压风机、制造商
Professional air pump design、manufacturer

升 鸿 大 风 机 械 设 备 有 限 公 司
SHENGHONG DAFENGMECHANICAL EQUIPMENT CO., LTD

Certified by International
Standard Organization
ISO-9001



中国 - 台湾 - 品牌

2015高压风机选型手册-简体中文版
High pressure fan product manuals Simplified Chinese

目录 CONTENTS

气环泵的工作原理 Gas ring pump working principle	1
气环泵的结构组成和分解 Gas ring pump structure and decomposition	2
升鸿系列产品的特点与优势 product features and advantages of the Feng Paker	3-7
升鸿气环泵选型参考及附表 product selection of reference and schedule	8-12
EHS-1AC系列选型参数、曲线、尺寸 EHS-1AC series production parameters、curve、size	13-16
EHS-2-3AC系列选型参数、曲线、尺寸 EHS-2-3AC series production parameters、curve、size	17-20
EHS-2-3AC系列选型参数、曲线、尺寸 EHS-2-3AC series production parameters、curve、size	21-24
EHS-3-3AC系列选型参数、曲线、尺寸 EHS-3-3AC series production parameters、curve、size	25-28
EHS-4-3AC系列选型参数、曲线、尺寸 EHS-4-3AC series production parameters、curve、size	29-32
EHS-5-3AC系列选型参数、曲线、尺寸 EHS-5-3AC series production parameters、curve、size	33-35
EHS-6-3AC系列选型参数、曲线、尺寸 EHS-6-3AC series production parameters、curve、size	36-41
EHS-7/8-3AC系列选型参数、曲线、尺寸 EHS-7/8-3AC series production parameters、curve、size	42-46

EHS-9-3AC系列选型参数、曲线、尺寸 EHS-9-3AC series production selection parameters、curve、size	47-52
EHS2-1AC系列高压风机选型参数、曲线 EHS2-1AC series of selection parameters、high pressure fan curve、size	53-54
EHS2-3AC系列高压风机选型参数、曲线 EHS2-3AC series of selection parameters、high pressure fan curve、size	55-61



江蘇升鴻大風機械設備有限公司
JIANGSU SHENGHONG DAFENG MACHINERY EQUIPMENT CO., LTD

高壓風機|氣環式真空泵|側通道鼓風機的研發生產
High pressure fan | Air ring vacuum pump | Research and production of side channel blower

張小文 先生 銷售工程師 Mr. Zhang Xiaowen Sales Engineer

150 0067 1868

shenghongfj@foxmail.com

www.shenghonggufengji.com



微信扫碼，添加我
Scan WeChat and add me

通訊地址：中國·江蘇省鎮江市大港新區航天航空產業園鳳棲路江蘇升鴻
Mailing Address: Fengqi Road, Aerospace Industry Park, Dagang New Area, Zhenjiang City, Jiangsu Province, China Shenghong, Jiangsu Province

气环泵工作原理 Operating Principle

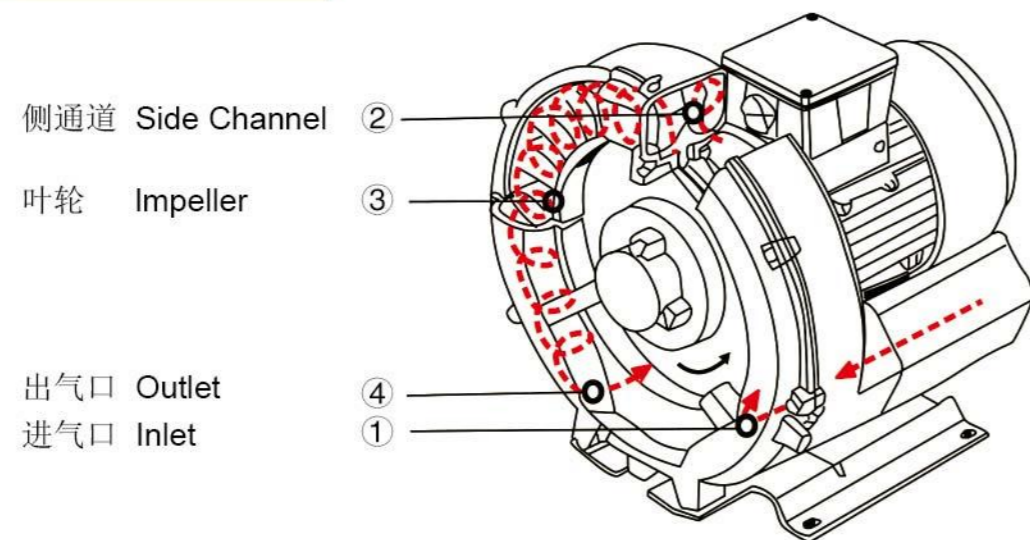

气环泵叶轮直接安装在电机转子上,是完全地无接触压缩。由于泵轴安装在压缩腔外,所以即使工作在最大的压差下,也能确保机械的最大工作可靠性。气体由吸气口 1 吸入,但它进入侧通道 2 以后,旋转叶轮方向上给气体一个速度同时叶片上离心力使气体向外加速且压力增加。随着旋转的进行,气体的动能增加,使得沿侧通道的气体压力进一步增加。随着侧通道在出口变窄,气体被挤出叶片并通过出口消声器 4 排出泵体。

The impellers are mounted directly on the motor shaft for noncontact compression entirely without friction. Maximum operational reliability, even at high differential is ensured by the arrangement of the bearings outside the compression chamber.

The gas is taken in through the inlet 1. As it enters the side channel 2, the rotating impeller 3 imparts velocity to the gas in the direction of rotation. Centrifugal force in the impeller blades accelerates the gas outward and the pressure increases. Every rotation adds kinetic energy.

Resulting in the further increase of the pressure along the side channel. The side channel narrows at the rotor, sweeping the gas off the impeller blades and discharging it through the outlet silencer 4 where it exits the side channel blower.

气环泵组成结果谱图 Vacuum pump chart

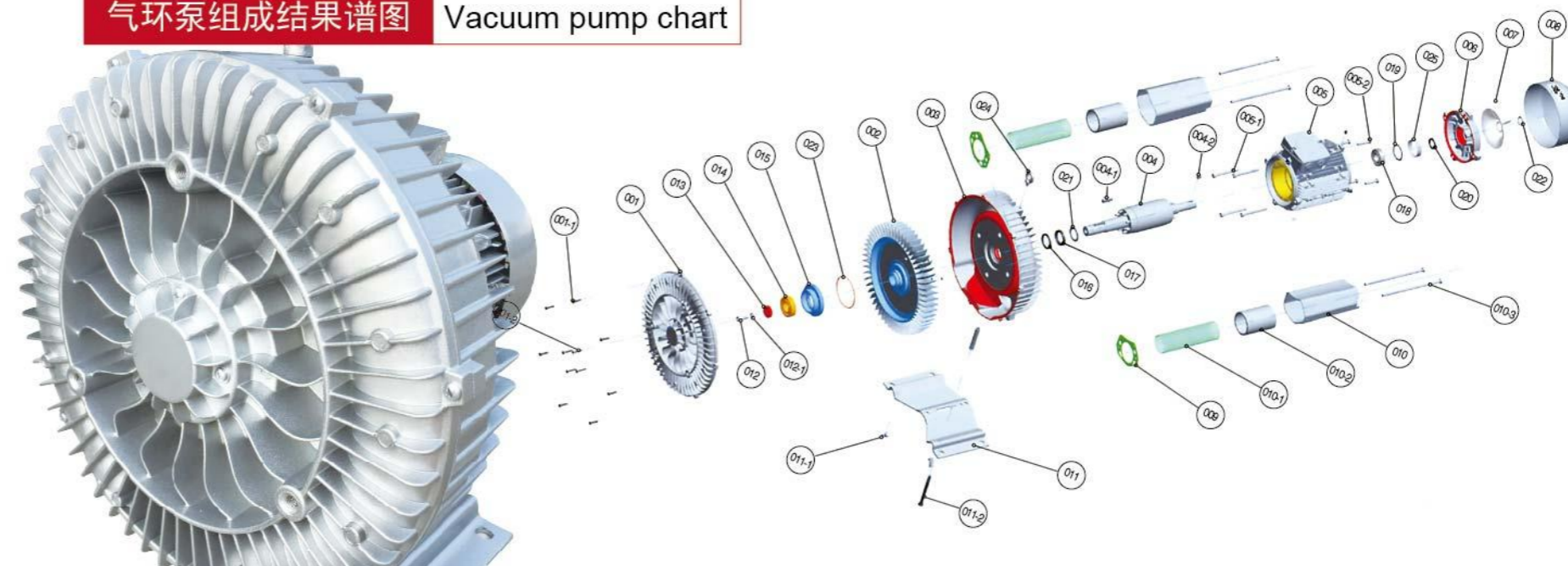

编号	部件名	编号	部件名	编号	部件名	编号	部件名
001	泵盖 pump cover	011	底座 base	021	垫片 washer	005-2	螺钉 screw
002	叶轮 impeller	012	螺钉 screw	022	卡簧 circlip	010-1	消音网罩 mesh enclosure
003	泵体 pump casing	013	转子压板 pressure-plate	023	O 型密封圈 O-ring	010-2	消音海绵 soundproof sponge
004	电机转子 rotator	014	轴承 screw	024	吊环 hand ring	010-3	螺钉 screw
005	电机 motor	015	固定座 fixing base	025	轴承包络圈 wrap ring	011-1	螺钉 screw
006	电机后盖 motor cover	016	毡环 felt ring	001-1	螺钉 screw	011-2	螺钉 screw
007	风叶 fan	017	油封 oil seal	001-2	螺钉 screw	012-1	弹簧垫圈 lock washer
008	风罩 fan cover	018	轴承 screw	004-1	平键 flat key		
009	泵体纸垫 paper pad	019	波浪垫片 ware washer	004-2	平键 flat key		
010	消音筒 Muffle Tube	020	油封 oil seal	005-1	螺钉 screw		

升鸿特点优势 Features and advantages

- 改进传统工艺,是轴承前置,增加了工作稳定性。
Improvement of traditional crafts, bearing front, increased stability.
- 采用部分进口配件,延长使用寿命。
Using some of the imported parts, lengthen service life.
- 机壳采用优质铝合金一次性压铸成型,零部件的加工在切削加工中完成,保证精度改进传统工艺。
The shell adopts the high quality aluminum alloy one-time die-casting molding, machining parts Completed in the cutting process, ensure the accuracy improvement of traditional technology.
- 叶轮的设计经过精确计算论证,使同功率下性能比同类产品提高 20%。
The design of the impeller through the accurate calculation of argumentation, the performance under the same power ratio Similar products increased by 20%.

性能优势 The performance advantages

- 100% 无油,无水压缩,所有的气环真空泵的电机均为 IP55 的防护等级,F 级绝缘。
- 双频 (50/60HZ) 及宽电压能满足几乎世界上所有地区的电压等级,轴承外置设计,能承受较高的工作温度,提高了运行可靠性和使用寿命。
- 引进变频驱动新概念,比用普通电机驱动性能最大可以提高到 300%,叶轮与泵体间的独特的密封形式减少气体压缩过程中的压力损失。
- 泵壳、叶轮采用压铸模型成型,坚固耐用,散热优良,采用德国、日本进口精密机床加工切割,保证精度与品质,气泵表面经过防护漆处理。
- 产品经过严格机械、电气等各方面性能测试,采用 PROE、UG、CAD 等电脑辅助设计软件和运动模拟仿真演示。
- 100% oil free compressed gas,water ring vacuum pump,motor,all are the protection calss IP55,class F insulation.
- Dual frequency (50/60HZ)and wide voltage can meet almost all regions of the world the voltage level, the external design of the bearing, can bear high woring temperatuer, improves the reliability and sevice life.
- The introduction of variable frequency sriver new concept, than the maximum performance can be driven by a commom motor is improved to 300%, impeller and pump body seal forms the unique reduced pressure gas pressure loss in the process of compression.
- Pump casing, impeller die-casting molding, sturdiness and durability, excellent heat dissipation, imported Japan Germany, precision machine tool cutting, ensure the accuracy and quality, air pump through the surface of protective paint processing
- Products through the strict mechanical, electrical performance test, simulation demonstrate the use of PROE, UG, CAD and other computer aided design software and motion.

规格齐全 享誉全球 Specifications complete, famous all over the world

- 多达100多种的产品型号可满足您各种具体应用的要求，采用宽电压双频(50/60HZ) 电机，防护等级IP55(绝缘等级F级)，在世界的任何地方，都可以应用升鸿气环真空泵。并且无论是在欧洲、中东、东南亚，升鸿都能在很短的时间内交货，我们批量的产品可以随时满足您的需求。
- As many as 100 kinds of products can meet your specific application of various requirements, with wide voltage frequency (50/60HZ) motor, protection class IP55 (class F insulation), anywhere in the world, can be applied to wind morale ring cacuum pump. shatever in Europe, Middle East, Southeast Asia, can be delivered in a very short period of time, our volume inventory of products can meet your needs.

变频驱动 高效节能 Variable frequency drive energy efficiency

- 当在电机或控制柜上直接安装一个变频频率，同样型号的气环真空泵、压缩机可以在节能的同时处理更多流量的气体。这是由于精确的控制系统总是提供您需要的准确动力，从而避免额外的气量消耗，使系统运行费用大大减低。
- Directly when installing a variable frequency motor or the control cabinet, the gas ring vacuum pump, compressor of the same type can handle more traffic in energy saving at the same time. The is because always precise control system to provide accurate power you need, so as to prevent additional gas consumption, the system running cost greatly reduced.

灵活的安装方式 Flexibe installation

- 能按任何轴向安装，没有任何限制，这意味着降低了空间要求和安装费用。
- Can be mounted in any direction, without any restrictions, which means that reduces the space requirements and installation costs.

全面的质量管理 Total quality management

- 根据ISO9001:2000的标准，升鸿总是把质量和客户满意放在第一位，从最初的设计、开发、生产、订单处理以及随后的顾客支持，我，我们总是提供给你最好的、遍及整个产品全部周期的系统服务。升鸿产品的技术进步和市场成功的高质量是密不可分。为了保证产品的高质量，从产品的设计到供货，升鸿已建立了用于监督生产各个环节的可靠的质量保证系统。这个质量保证系统符合相关的标准约定，并通过CE认证，满足全世界的要求。同时，欢迎OEM、ODM等定制品开发，针对客户的使用要求和场合开发满意的新产品。
- According to the standard of ISO9001:2000, wind, always put the quality and customer satisfaction in the first place, from the initial design, development, production, order processing and subsequent customer support, we will always provide you the best service, system throught the product cycle. Technology progress and market success of wind and products with its high quality is inseparable. In order to guarantee the high quality of products, from product design to delivery, wind, have been established for the reliable quality of each link of supervision to ensure production system. The quality assurance system in conformity with the agreed standards, and through the ISO9001 certification, to meet the requirements of the world. Also welcome OEM, ODM set product development, new product usage requirements and situations develop satisfactory.

最高压差 EHS2 The high pressure difference EHS2

- 我们富有革命的EHS2气环真空泵能产生高达1,000mbar的压差——远远高于其他任何的气环式压缩机。截至目前，能产生压差范围的其它系统要比我们的EHS2体积更庞大，噪音更高，而且容易磨损。现在，除了拥有低噪音，无磨损等这些优点外，我们的EHS2还能在苛刻的条件下应用。我们的工程师和设计者还在不断努力以使我们的产品变得更加安静。EHS2气环真空泵能在不停机维护的条件下连续工作20,000小时。

- Our revolutionary EHS2 gas ring vacuum pumps can generate up to 1000mbar of differential pressure——far higher than any other of the gas piston compressor At present, the other system can produce pressure range than our EHS2 volume larger, more noise, and easy to wear Now, in addition to having low noise, no wear ect. these advantages, our EHS2can also be used in more severe conditions.Our engineers and designers are trying to make our products become more quiet. EHS2 gas ring vacuum pump can work continously 20000 hours without downtime maintenance conditions.



如何选型 How to select model

- 升鸿气泵选型有哪些型号、参数? / ShengHong air selection which models, parameters?
- 如何选出性能最匹配的产品? / How to select the most matching performance products?



型号说明 Demonstration of the type

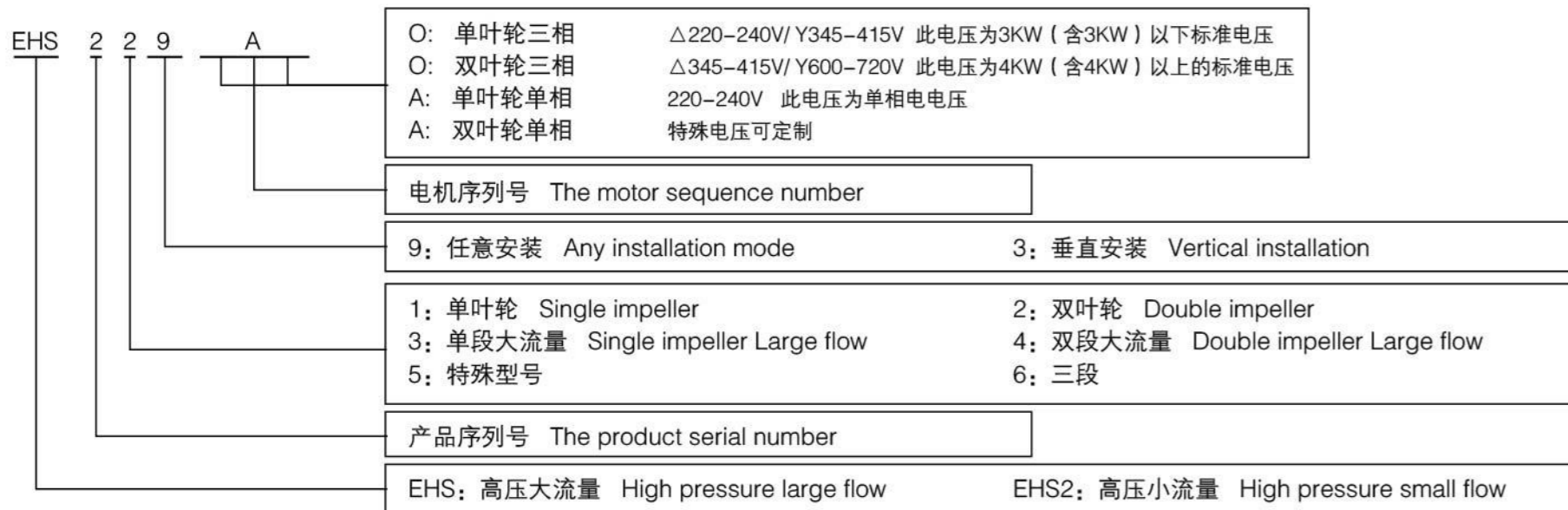

绝对压力 Absolute pressure

绝对压力是以理想真空（绝压为零）为基准而得到的测量值。所以绝压是比参考值大。

Absolute pressure in vacuum (absolute pressure is zero) as the reference and the measured values obtained. So the pressure is greater than the reference value.

表压 Gauge pressure

表压是指高于标准大气压力的测量值。即以标准大气为基准，因此实际测量值总是比基准值大。

Gauge pressure is that measurement is higher than the standard atmospheric pressure value. The standard atmosphere for reference, so the actual measured value is large than the reference value.

真空度 Vacuum degree

真空度是指低于标准大气压力的测量值。测量基准任仍为标准大气压，所以实际测量值小。

The vacuum is that measurement is lower than standard atmospheric pressure value. Measurement benchmark is the standard atmospheric pressure, so the actual measured value.

换算表 Conversion table

风量 Air volume		
初始单位	换算因子	目标单位
The initial unit	Conversion constant	Target unit
l/min	0.06	m ³ /h
gal/min	0.227	m ³ /h
ft ³ /min(cfm)	1.699	m ³ /h
m ³ /h	16.667	l/min
m ³ /h	4.403	gal/min
m ³ /h	0.588	ft ³ /min(cfm)

压力 Pressure		
初始单位	换算因子	目标单位
The initial unit	Conversion constant	Target unit
Pa	0.01	mbar
hpa	1.0	mbar
kpa	10.0	mbar
mmH20(mmAq)	0.098	mbar
mH20	98.07	mbar
at	980.7	mbar
inchH20	2.491	mbar
PSII pdf/in2	68.948	mbar

选型及使用须知 Selection and use knowledge

1、DIN VDE 0105或IGC 364 规定，非资格人员不得从事电气设备的工作。

资格人员：是指有厂区安全负责人授权的人员。他们根据自有的培训、经验、相关标准的知识及对事故预防的能力来完成某项必要的工作，同时能意识到潜在的危险并采取必要的防范措施。有必要的生命急救知识，熟悉相关的生命救护设备。

DIN VDE 0105 or IGC 364 regulations, non qualified personnel shall not be engaged electrical equipment work. Qualified personnel:refers to the factory safety responsible person authorized personnel. According to their own training, experience, knowledge and ability related standards on prevention of accidents to complete a necessary work, and to realize the potential The risk and take the necessary preventive measures. It is necessary to life first aid knowledge, familiar with the life rescue equipment related.

2、随设备而来的操纵说明书不可能包含所有涉及要素的详细信息，尤其不可能把每一种可能的安装，操作及维护方式都涉及到。因此这些操作手册只包括能让资格人员正确操作机器或设备的必要信息。因此有必要澄清一下，如果缺乏产品的详细参数，或有关操作等疑问，请根据产品的设备类型和加工代号，联系我们。

Came with the equipment operating instructions may not contain detailed information all of the factors related, in particular, can not put every possible intallation,are related to the operation and maintenance of way. The manual includes only can let the qualification information necessary for correct operation personnel of machines or equipment. Therefore, it is necessary to clarify, if lack of detailed parameters of products, or related questions, please according to the type of equipment and processing code for this product, contact us.

3、允差：电机符合DIN EN 60 034/DIN IEC 34-1标准，绝缘等级F。

Tolerance standard: motor meets the standard of DIN EN 60 034/DIN IEC 34-1, insulation class F.

4、在选型时注意，要根据使用现场的具体情况，是侧重于流量还是压力等相关因素，选择最合适，性价比最高，最节省能源的方案。必要时使用释压阀、过滤器等辅助配件，以便更好的发挥设备的性能和匹配现场。

In the selection of attention when, according to the specific circumstances of the scene, is focused on the flow or pressure and other related factor, choose the most suitable, cost-effective, the energy is saved. The use of pressure release valve, filter when necessary And other auxiliary parts, in order to better play the performance of equipment and matching field.

5、启动前及启动准备检查紧固件有无松动、脱落，外壳不变形错位，完好无损/接线方式、电源电压等符合要求/外壳接地，安装漏电保护器/检查电机转向是否正常运转时，应平稳。震动、温升噪音均正常。

Start up and ready to check the fastener without loosening, shed off 5 before the start, shell not deformation disloaction, intact/wiring, power supply voltage, meet the requirement/shell grounding , installation of leakage protector/check the shift motors ensuer normal operation should be smooth, vibration, noise, temperature rise were normal.

6、气泵在转运过程中，如出现噪音异常增大、尖叫、振动加大。温度异常升高应立即切断电源进行检查，待故障排除后再通电运转。

Pump during operation, such as nosie, vibration, increase the abnormal increase of screaming, abnormal temperature rise should be cut off the power supply immediately checked, troubleshooting to be re energized.

严禁气泵在有连接管道的情况下进行通电启动！

No air pump in a connection pipeline of start power!

严禁进气口采用硬链接，必须采用软连接！

No inlet using hard links, must use soft connection!

EHS/1AC (单、双级) 气环真空泵型号及性能参数表 (IP55 50/60HZ)

EHS/1AC(Single, double impeller) Gas ring vacuum pump models and the performance parameters table(IP55 50/60HZ)

型号 (EHS) Model	单级	马达额定参数				最大 排吸流量 Max airflow m³/h	额定 真空压力 rated Vacuum mbar	额定 压缩压力 rated compress mbar	噪音 noises db(A)	重量 weight Kg
	双级	频率	功率	电压	电流					
	single double	frequency HZ	power KW	voltage V	current A					
EHS-229-A	单	50	0.4	200-240V	2.7	80	-120	130	53	10
		60	0.5	200-240V	3.2	98	-150	160	56	
EHS-239-A	单	50	0.4	200-240V	2.7	100	-110	110	54	11
		60	0.5	200-240V	3.2	120	-130	140	57	
EHS-249-A	单	50	0.55	200-240V	3.7	95	-120	130	57	13
		60	0.62	200-240V	4.9	110	-120	130	60	
EHS-259-A	单	50	0.7	200-240V	4.8	100	-150	150	55	14
		60	0.8	200-240V	4.1	120	-150	160	57	
EHS-269-A	双	50	1.3	200-240V	7.3	120	-240	280	58	17
		60	1.5	200-240V	8.3	145	-230	260	60	
EHS-279-A	单	50	0.7	200-240V	4.8	145	-100	100	56	14
		60	0.8	200-240V	4.1	165	-110	100	58	
EHS-319-A	单	50	0.7	200-240V	4.5	145	-120	120	63	15
		60	0.83	200-240V	5.6	175	-130	130	64	
EHS-329-A	单	50	0.85	200-240V	5	145	-160	160	63	16
		60	0.95	200-240V	5.8	175	-160	160	64	
EHS-339-A	单	50	1.3	200-240V	7.3	145	-170	200	63	17
		60	1.5	200-240V	7.8	175	-210	220	64	

EHS/1AC (单、双核) 气环真空泵型号及性能参数表 (IP55 50/60HZ)

EHS/1AC (Single, double impeller) Gas ring vacuum pump models and the performance parameters table (IP55 50/60HZ)

型号 (EHS) Model	单级	马达额定参数				最大 排吸流量 Max airflow m³/h	额定 真空压力 rated Vacuum mbar	额定 压缩压力 rated compress mbar	噪音 noises db(A)	重量 weight Kg
	双级	频率	功率	电压	电流					
	single double	frequency HZ	power KW	voltage V	current A					
EHS-3315-A	双	50	1.5	200-240V	9	150	-260	260	66	28
		60	1.75	200-240V	9.5	180	-300	290	69	
EHS-349-A	单	50	0.85	200-240V	5.2	180	-100	110	64	16
		60	0.95	200-240V	5.8	210	-100	110	66	
EHS-359-A	单	50	1.3	200-240V	7.3	180	-150	140	64	17
		60	1.5	200-240V	8.3	210	-140	130	66	
EHS-429-2A	单	50	1.3	200-240V	7.3	210	-170	170	64	22
		60	1.5	200-240V	7.5	255	-150	140	70	
EHS-439-A	单	50	1.5	200-240V	10.4	210	-200	190	64	24
		60	1.75	200-240V	11.2	255	-220	210	70	
EHS-429-A	单	50	2.2	200-240V	10	210	-220	210	64	26
		60	2.55	200-240V	11	255	-240	230	70	
EHS-449-A	单	50	1.5	200-240V	10.4	270	-150	140	65	26
		60	1.75	200-240V	11.2	330	-120	110	71	
EHS-629-A	单	50	2.2	200-240V	12.8	318	-210	200	72	30
		60	2.55	200-240V	12.8	376	-210	200	74	

EHS 真空压缩选型曲线 1AC/ Vacuum compression type curve

Vacuum Selection diagram 50 Hz--真空选型图表 50Hz

Compressor Selection Diagram 50 Hz--压缩选型图表 50Hz

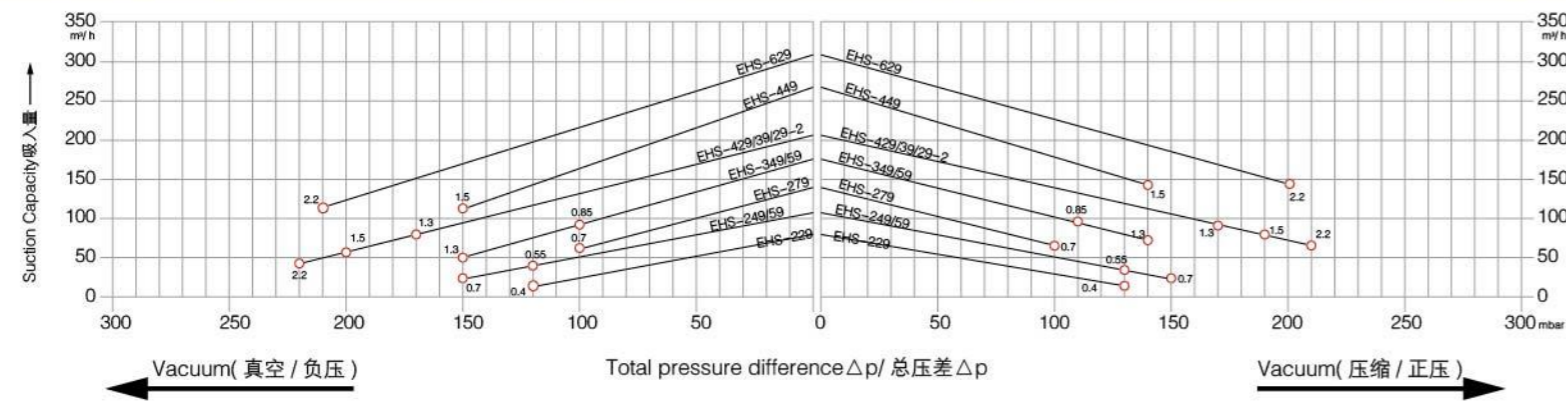

Vacuum Selection diagram 60 Hz--真空选型图表 60Hz

Compressor Selection Diagram 60 Hz--压缩选型图表 60Hz

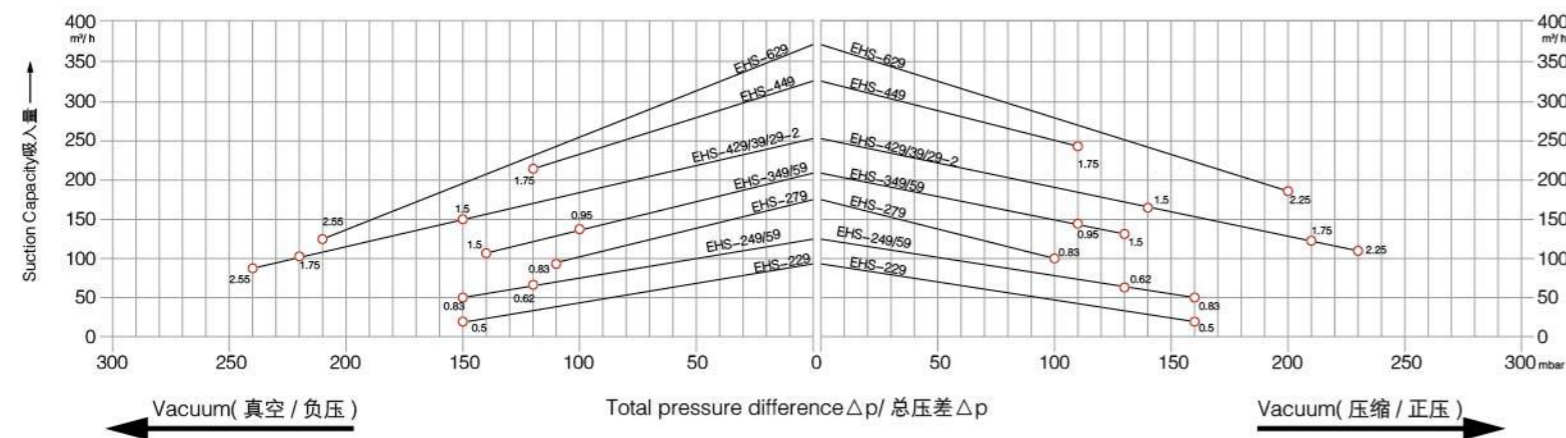

EHS真空压缩选型曲线 1AC/ Vacuum compression type curve

Vacuum Selection diagram 50 Hz--真空选型图表 50Hz

Compressor Selection Diagram 50 Hz--压缩选型图表 50Hz

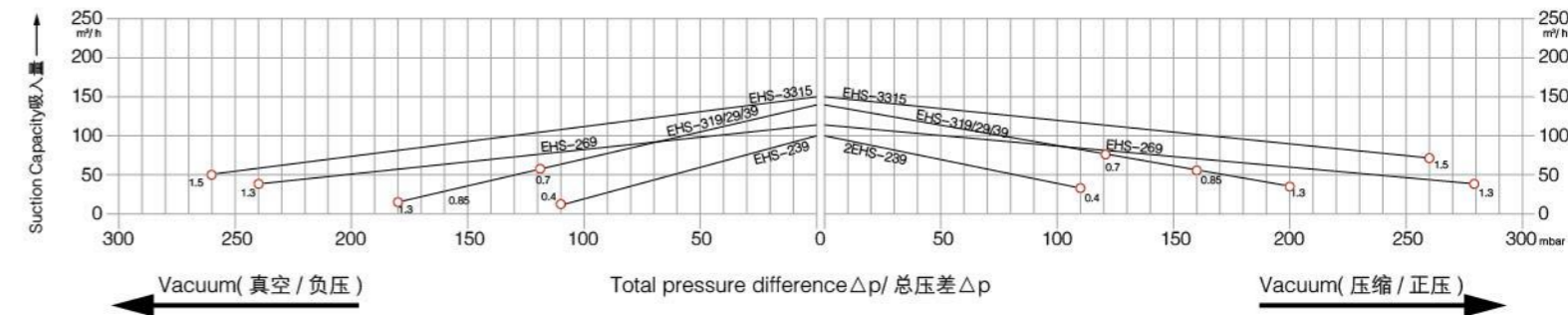

Vacuum Selection diagram 60 Hz--真空选型图表 60Hz

Compressor Selection Diagram 60 Hz--压缩选型图表 60Hz

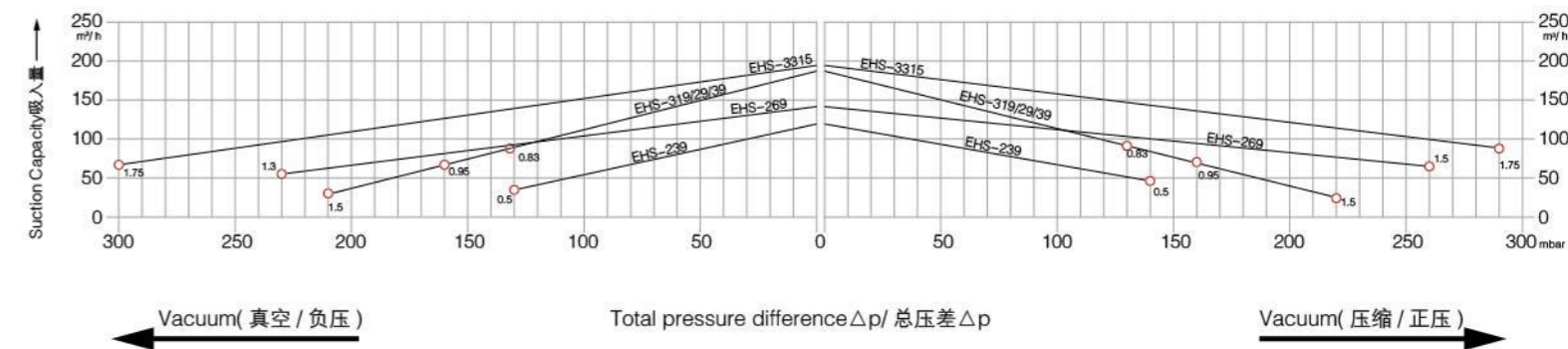

EHS-2/3AC (单、双级) 气环真空泵型号及性能参数表(IP55 50/60HZ)

EHS-2/ 3AC (Single,double impeller) Gas ring vacuum pump models and the performance parameters table (IP55 50/60HZ)



型号 (EHS) Model	单级	马达额定参数				最大 排吸流量 Max airflow m³/h	额定 真空压力 rated Vacuum mbar	额定 压缩压力 rated compress mbar	噪音 noises db(A)	重量 weight Kg	
	双级	频率	功率	电压	电流						
	single double	frequency HZ	power KW	voltage V	current A						
EHS-229	单	50	0.4	200-240Δ	345-415Y	2.6Δ/1.5Y	80	-120	130	53	10
		60	0.5	220-275Δ	380-480Y	2.6Δ/1.5Y	98	-150	160	56	
EHS-239	单	50	0.4	200-240Δ	345-415Y	2.6Δ/1.5Y	105	-120	130	54	11
		60	0.5	220-275Δ	380-480Y	2.6Δ/1.5Y	120	-150	150	57	
EHS-249	单	50	0.7	200-240Δ	345-415Y	3.8Δ/2.2Y	105	-120	130	54	12
		60	0.83	220-275Δ	380-480Y	3.8Δ/2.2Y	120	-160	180	57	
EHS-2308	双	50	0.7	200-240Δ	345-415Y	3.8Δ/2.2Y	85	-210	240	55	15
		60	0.83	220-275Δ	380-480Y	3.75Δ/2.15Y	102	-250	250	61	

EHS-2 真空压缩选型曲线 3AC/ Vacuum compression type curve

Vacuum Selection diagram 50 Hz--真空选型图表 50Hz

Compressor Selection Diagram 50 Hz--压缩选型图表 50Hz

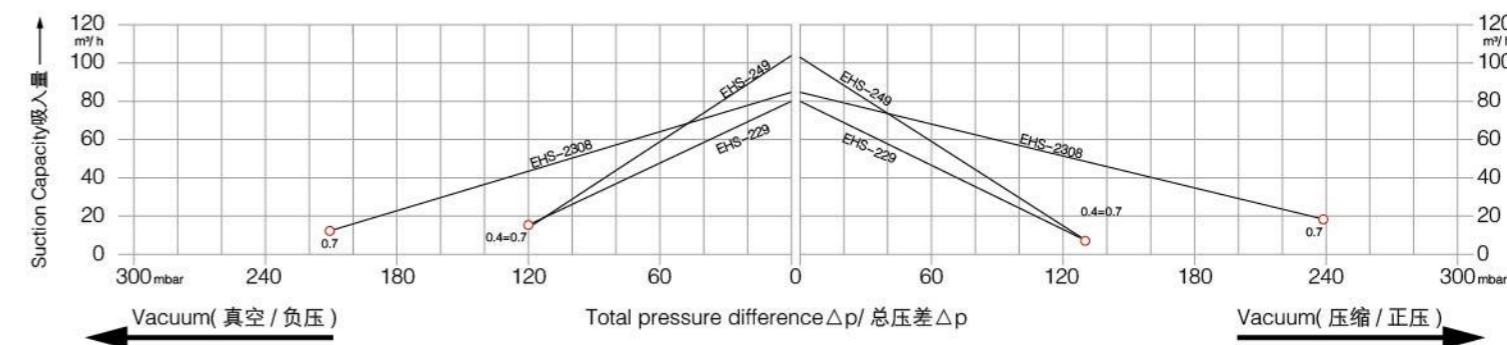

Vacuum Selection diagram 60 Hz--真空选型图表 60Hz

Compressor Selection Diagram 60 Hz--压缩选型图表 60Hz

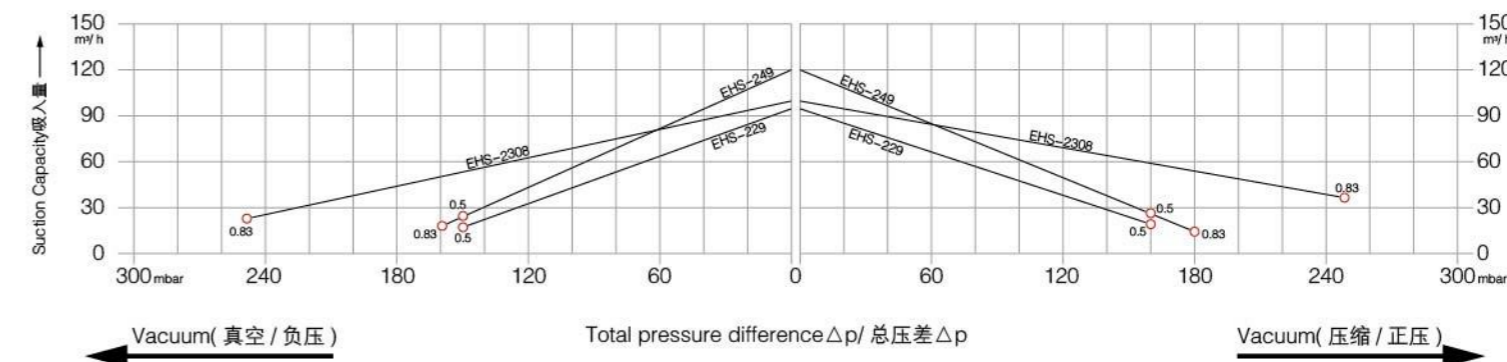

EHS-2 单级 安装尺寸 / Single stage mounting dimensions

EHS-2

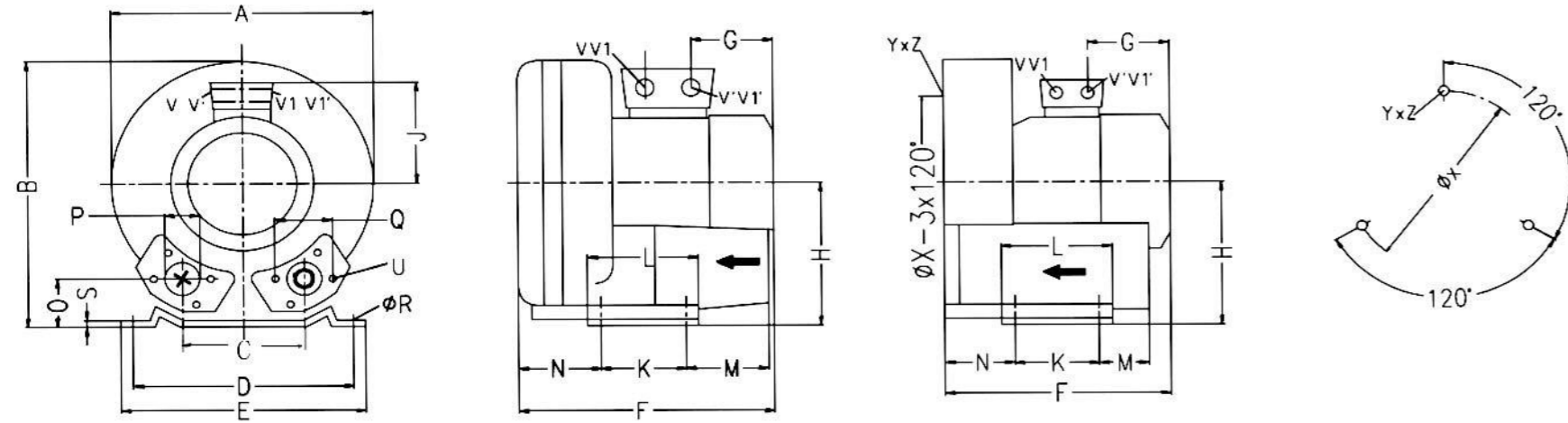

型号 Type	相位	A	B	C	D	E	F	G	H	J	K	L	M	N	O	P	Q	fR	S	U	V(1~)	V'(1~)	V1(3~)	V1'(3~)	YxZ	X-Holes	fX
EHS-229	3~	246	247	90	205	230	256	135	128	111	83	108	75	71	39	G1 _{1/4}	64	10	2.5	M6x17			M25x1.5	M16x1.5	M6x15	0° /120° /240°	140
EHS-239	3~	246	247	90	205	230	267	135	128	111	83	108	75	82	39	G1 _{1/4}	64	10	2.5	M6x17			M25x1.5	M16x1.5	M6x15	0° /120° /240°	140
EHS-249	3~	246	247	90	205	230	267	135	128	111	83	108	75	82	39	G1 _{1/4}	64	10	2.5	M6x17			M25x1.5	M16x1.5	M6x15	0° /120° /240°	140
EHS-239-A	1~	246	247	90	205	230	267	135	128	111	83	108	75	71	39	G1 _{1/4}	64	10	2.5	M6x17	M16x1.5	M25x1.5			M6x15	0° /120° /240°	140
EHS-239-A	1~	246	247	90	205	230	267	135	128	111	83	108	75	82	39	G1 _{1/4}	64	10	2.5	M6x17	M16x1.5	M25x1.5			M6x15	0° /120° /240°	140

EHS-2 双级 安装尺寸 / Two stage mounting dimensions

EHS-2

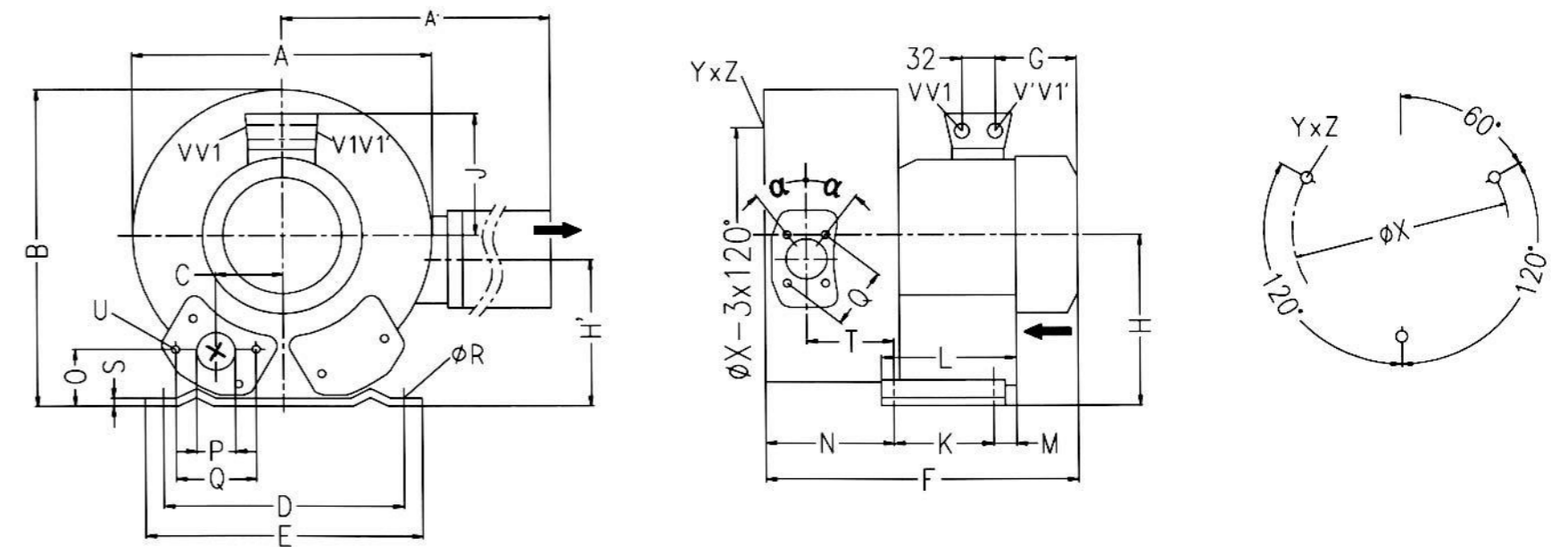

型号 Type	相位	A	A'	B	C	D	E	F	G	H	H'	J	K	L	M	N	O	P	Q	fR	S	T	U	V(1~)	V'(1~)	V1(3~)	V1'(3~)	a	fX	YxZ	X-Holes
EHS-2308	3~	284	316	270	45	205	230	316	135	128	106	111	83	108	75	130	39	G1 _{1/4}	64	10	2.5	88	M6x17			M25x1.5	M16x1.5	27°	140	M6x15	51° /171° /291°

EHS-2/3AC (单、双极) 气环真空泵型号及性能参数表(IP55 50/60HZ)

EHS-2/ 3AC (Single,double impeller) Gas ring vacuum pump models and the performance parameters table (IP55 50/60HZ)



型号 (EHS2 3AC) Model	单级	马达额定参数				最大 排吸流量 Max airflow m³/h	额定 真空压力 rated Vacuum mbar	额定 压缩压力 rated compress mbar	噪音 noises db(A)	重量 weight Kg	
	双级	频率	功率	电压							电流 current A
	single double	frequency HZ	power KW	voltage V							
EHS-259	单	50	0.55	200-240△	345-415Y	2.8△/1.6Y	100	-120	130	55	11
		60	0.63	220-275△	380-480Y	3.0△/1.7Y	120	-120	140	57	
EHS-269	单	50	0.7	200-240△	345-415Y	3.8△/2.2Y	100	-150	170	55	12
		60	0.83	220-275△	380-480Y	3.8△/2.2Y	120	-160	180	57	
EHS-279	单	50	0.55	200-240△	345-415Y	2.8△/1.6Y	140	-60	60	56	12
		60	0.63	220-275△	380-480Y	3.0△/1.7Y	165	-40	40	58	
EHS-289	单	50	0.7	200-240△	345-415Y	3.8△/2.2Y	140	-100	100	56	13
		60	0.83	220-275△	380-480Y	3.8△/2.2Y	165	-110	100	58	
EHS-2318	双	50	0.85	200-240△	345-415Y	4.2△/2.4Y	110	-200	230	58	17
		60	0.95	220-275△	380-480Y	4.0△/2.3Y	130	-240	240	60	
EHS-2328	双	50	1.3	200-240△	345-415Y	5.7△/3.3Y	110	-260	310	58	18
		60	1.5	220-275△	380-480Y	6.0△/3.5Y	130	-260	320	60	

EHS-2 真空压缩选型曲线 3AC/ Vacuum compression type curve

Vacuum Selection diagram 50 Hz--真空选型图表 50Hz

Compressor Selection Diagram 50 Hz--压缩选型图表 50Hz

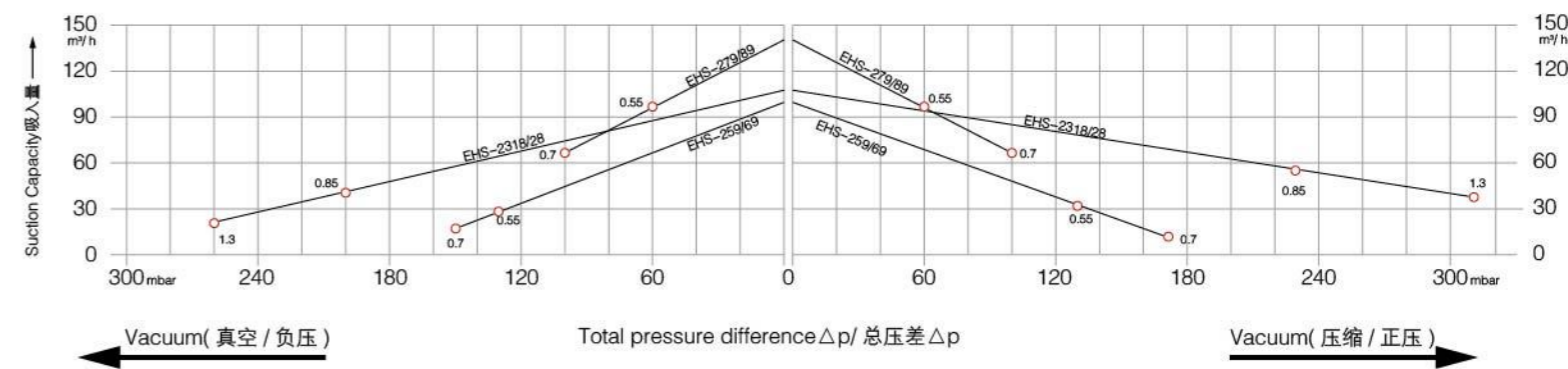

Vacuum Selection diagram 60 Hz--真空选型图表 60Hz

Compressor Selection Diagram 60 Hz--压缩选型图表 60Hz

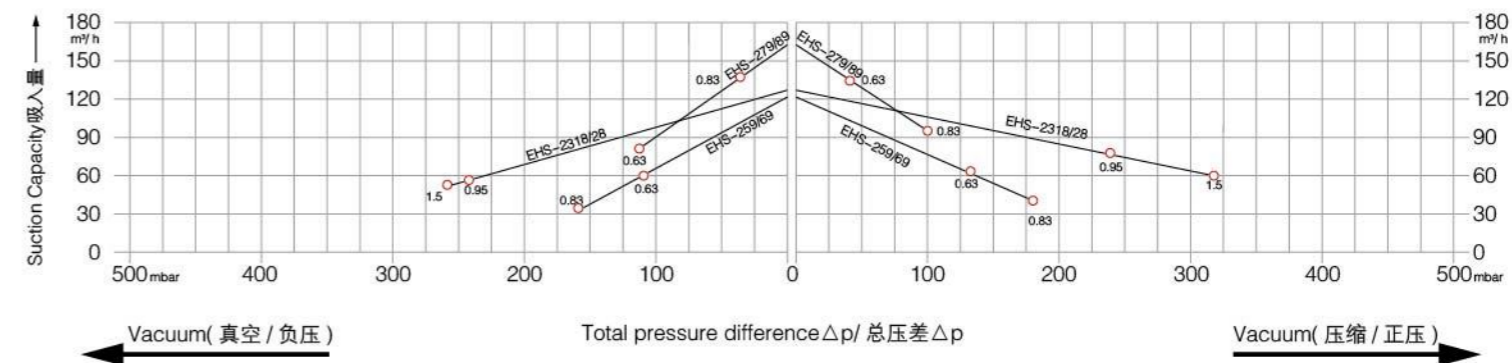

EHS-2 单级 安装尺寸 / Single stage mounting dimensions

EHS-2

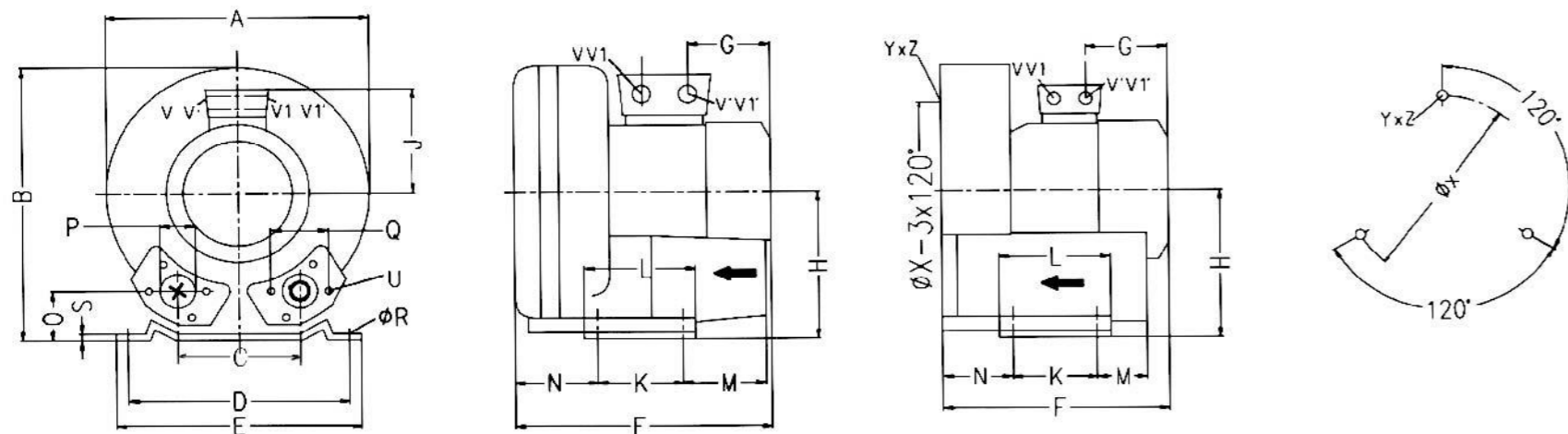

型号 Type	相位	A	B	C	D	E	F	G	H	J	K	L	M	N	O	P	Q	f	R	S	U	V(1~)	V'(1~)	V1(3~)	V1'(3~)	YxZ	X-Holes	f	X
EHS-259	3~	268	272	93	205	230	260	135	141	111	83	108	82	69	41	G _{1/4}	64	10	2.5	M6x17			M25x1.5	M16x1.5	M6x15	0° /120° /240°	160		
EHS-269	3~	268	272	93	205	230	260	135	141	111	83	108	82	69	41	G _{1/4}	64	10	2.5	M6x17			M25x1.5	M16x1.5	M6x15	0° /120° /240°	160		
EHS-279	3~	268	272	93	205	230	276	135	141	111	83	108	82	85	41	G _{1/4}	64	10	2.5	M6x17			M25x1.5	M16x1.5	M6x15	0° /120° /240°	160		
EHS-289	3~	268	272	93	205	230	276	135	141	111	83	108	82	85	41	G _{1/4}	64	10	2.5	M6x17			M25x1.5	M16x1.5	M6x15	0° /120° /240°	160		
EHS-249A	1~	268	272	93	205	230	260	135	141	111	83	108	82	69	41	G _{1/4}	64	10	2.5	M6x17	M25x1.5	M16x1.5			M6x15	0° /120° /240°	160		
EHS-259A	1~	268	272	93	205	230	260	135	141	111	83	108	82	69	41	G _{1/4}	64	10	2.5	M6x17	M25x1.5	M16x1.5			M6x15	0° /120° /240°	160		
EHS-279A	1~	268	272	93	205	230	276	135	141	111	83	108	82	85	41	G _{1/4}	64	10	2.5	M6x17	M25x1.5	M16x1.5			M6x15	0° /120° /240°	160		

EHS-2 双级 安装尺寸 / Two stage mounting dimensions

EHS-2

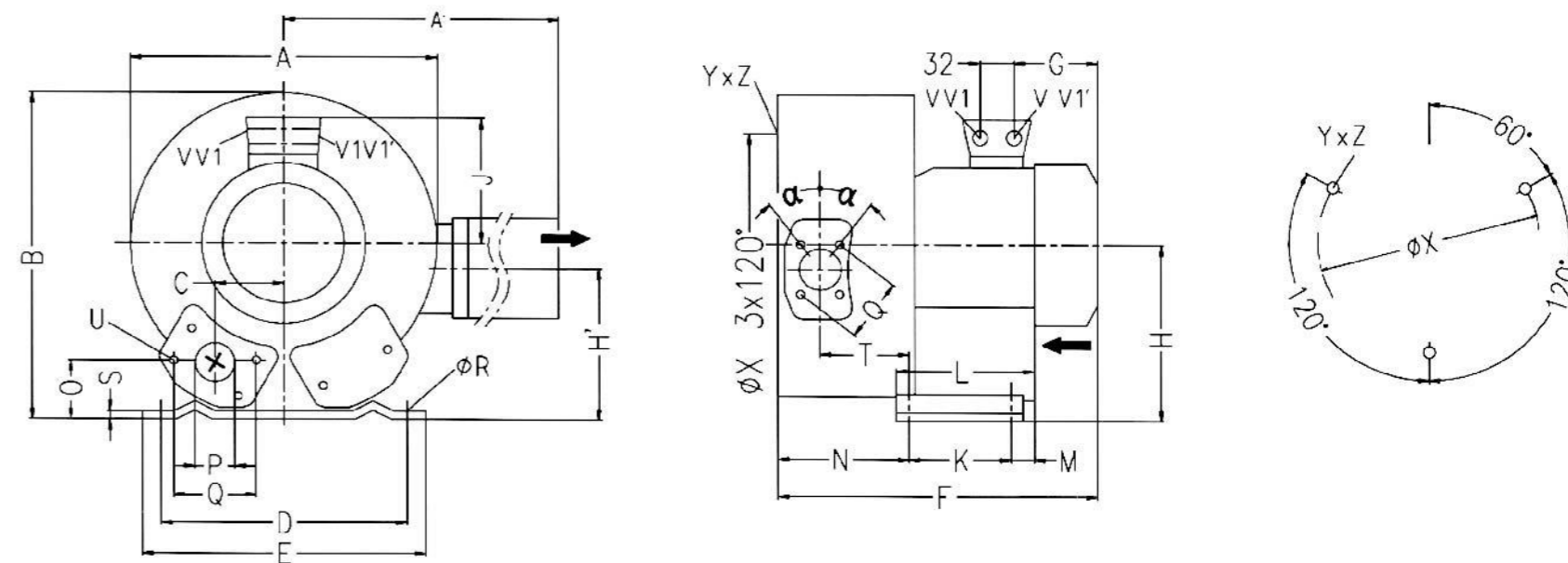

型号 Type	相位	A	A'	B	C	D	E	F	G	H	H'	J	K	L	M	N	O	P	Q	f	R	S	T	U	V(1~)	V'(1~)	V1(3~)	V1'(3~)	a	f	X	YxZ	X-Holes
EHS-2318	3~	293	324	286	47	205	230	354	160	141	114	120	83	108	82	138	41	G _{1/4}	64	10	2.5	92	M6x17			M25x1.5	M16x1.5	27°	160	M6x15	51° /171° /291°		
EHS-2328	3~	293	324	286	47	205	230	354	160	141	114	120	83	108	82	138	41	G _{1/4}	64	10	2.5	92	M6x17			M25x1.5	M16x1.5	27°	160	M6x15	51° /171° /291°		
EHS-269A	1~	293	324	286	47	205	230	354	160	141	114	120	83	108	82	138	41	G _{1/4}	64	10	2.5	92	M6x17	M25x1.5	M16x1.5			27°	160	M6x15	51° /171° /291°		

EHS-3/3AC (单、双级) 气环真空泵型号及性能参数表(IP55 50/60HZ)

EHS-3 3AC (Single,double impeller) Gas ring vacuum pump models and the performance parameters table (IP55 50/60HZ)

型号 (EHS-3 3AC) Model	单级	马达额定参数				最大 排吸流量 Max airflow m ³ /h	额定 真空压力 rated Vacuum mbar	额定 压缩压力 rated compress mbar	噪音 noises db(A)	重量 weight Kg	
	双级	频率	功率	电压	电流						
	single double	frequency HZ	power KW	voltage V	current A						
EHS-329	单	50	0.7	200-240△	345-415Y	3.8△/2.2Y	145	-120	120	63	13
		60	0.83	220-275△	380-480Y	3.75△/2.15Y	175	-130	130	64	
EHS-329-1	单	50	0.85	200-240△	345-415Y	4.0△/2.3Y	145	-160	160	63	16
		60	0.95	220-275△	380-480Y	3.85△/2.25Y	175	-160	160	64	
EHS-339	单	50	1.3	200-240△	345-415Y	5.7△/3.3Y	145	-170	200	63	17
		60	1.5	220-275△	380-480Y	6.0△/3.5Y	175	-210	220	64	
EHS-349	单	50	0.7	200-240△	345-415Y	3.8△/2.2Y	180	-70	70	64	14
		60	0.83	220-275△	380-480Y	3.8△/2.2Y	210	-50	50	65	
EHS-359	单	50	0.85	200-240△	345-415Y	4.2△/2.4Y	180	-120	120	64	17
		60	0.95	220-275△	380-480Y	4.0△/2.3Y	210	-90	70	65	
EHS-369	单	50	1.3	200-240△	345-415Y	6.6△/3.8Y	180	-170	220	64	18
		60	1.5	220-275△	380-480Y	6.9△/4.0Y	210	-200	160	65	
EHS-3319	双	50	1.6	200-240△	345-415Y	7.5△/4.3Y	150	-280	280	66	25
		60	2.05	220-275△	380-480Y	7.6△/4.4Y	180	-320	310	69	
EHS-3326	双	50	2.2	200-240△	345-415Y	9.7△/5.6Y	150	-330	440	66	27
		60	2.55	220-275△	380-480Y	10△/5.8Y	180	-350	420	69	

EHS-3 真空压缩选型曲线 3AC/ Vacuum compression type curve

Vacuum Selection diagram 50 Hz--真空选型图表 50Hz

Compressor Selection Diagram 50 Hz--压缩选型图表 50Hz

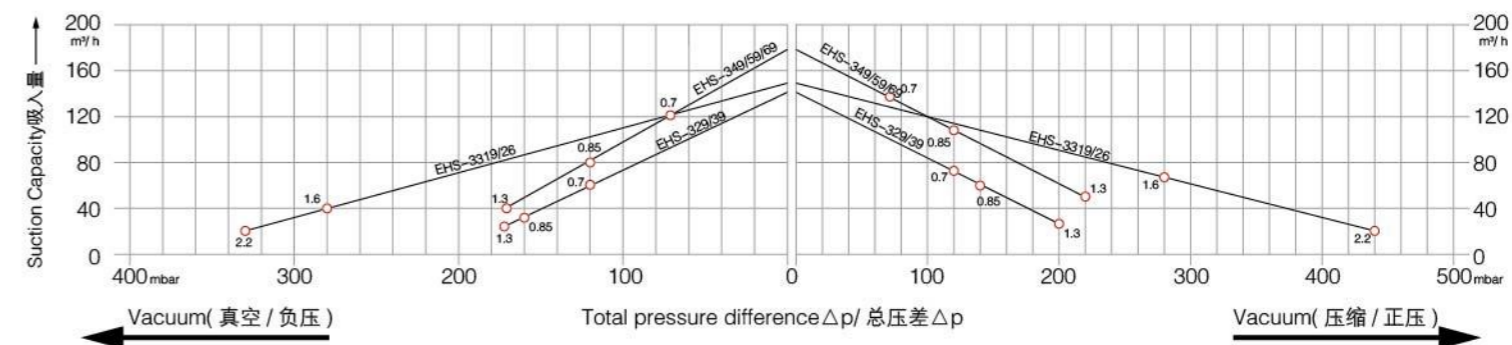

Vacuum Selection diagram 60 Hz--真空选型图表 60Hz

Compressor Selection Diagram 60 Hz--压缩选型图表 60Hz

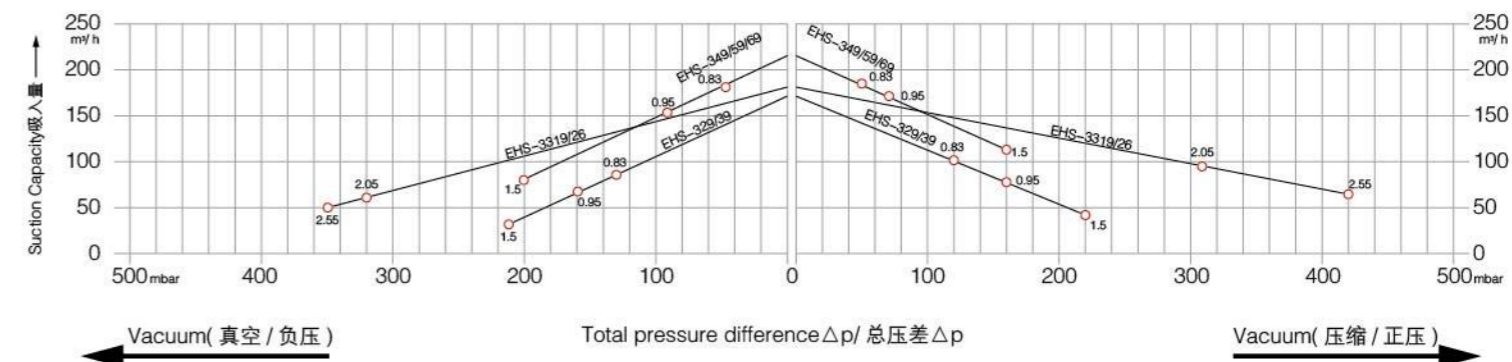

EHS-3 单级 安装尺寸 / Single stage mounting dimensions

EHS-3

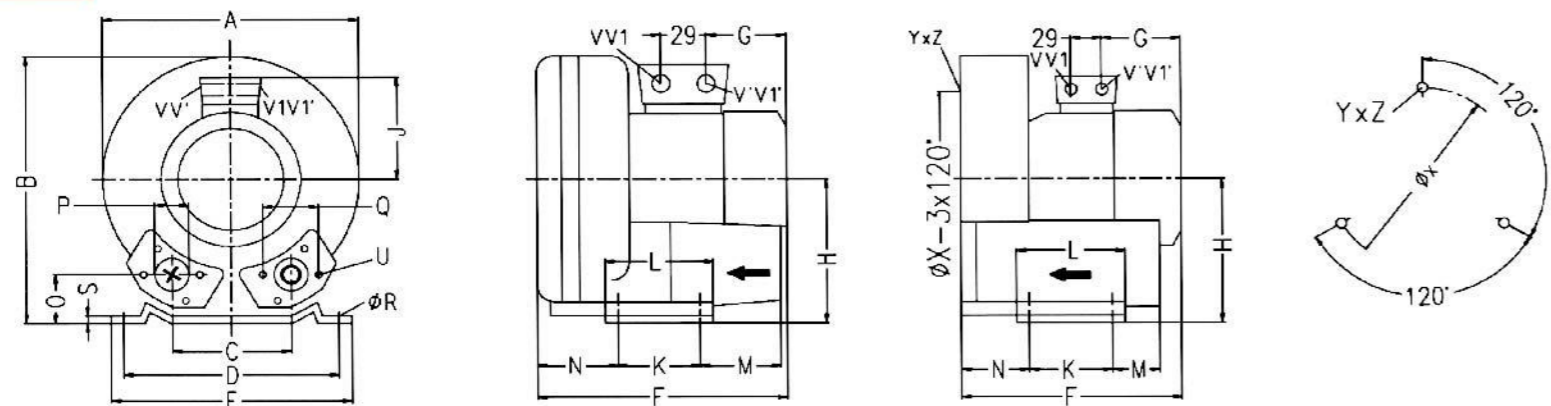

型号 Type	相位	A	B	C	D	E	F	G	H	J	K	L	M	N	O	P	Q	fR	S	U	V(1~)	V'(1~)	V1(3~)	V1'(3~)	YxZ	X-Holes	fX
EHS-329	3~	286	302	115	225	255	269	135	154	111	95	130	70	75	46	G _{1/2}	72	12	3	M6x19			M25x1.5	M16x1.5	M6x15	0° /120° /240°	174
EHS-329-1	3~	286	302	115	225	255	292	160	154	120	95	130	70	75	46	G _{1/2}	72	12	3	M6x19			M25x1.5	M16x1.5	M6x15	0° /120° /240°	174
EHS-339	3~	286	302	115	225	255	292	160	154	120	95	130	70	75	46	G _{1/2}	72	12	3	M6x19			M25x1.5	M16x1.5	M6x15	0° /120° /240°	174
EHS-349	3~	286	302	115	225	255	288	135	154	111	95	130	70	75	46	G _{1/2}	72	12	3	M6x19			M25x1.5	M16x1.5	M6x15	0° /120° /240°	174
EHS-359	3~	286	302	115	225	255	311	160	154	120	95	130	70	75	46	G _{1/2}	72	12	3	M6x19			M25x1.5	M16x1.5	M6x15	0° /120° /240°	174
EHS-369	3~	286	302	115	225	255	311	160	154	120	95	130	70	75	46	G _{1/2}	72	12	3	M6x19			M25x1.5	M16x1.5	M6x15	0° /120° /240°	174
EHS-329A	1~	286	302	115	225	255	294	160	154	120	95	130	70	75	46	G _{1/2}	72	12	3	M6x19	M16x1.5	M25x1.5	M25x1.5	M16x1.5	M6x15	0° /120° /240°	174
EHS-339A	1~	286	302	115	225	255	294	160	154	120	95	130	70	75	46	G _{1/2}	72	12	3	M6x19	M16x1.5	M25x1.5			M6x15	0° /120° /240°	174
EHS-349A	1~	286	302	115	225	255	311	160	154	120	95	130	70	75	46	G _{1/2}	72	12	3	M6x19	M16x1.5	M25x1.5			M6x15	0° /120° /240°	174
EHS-359A	1~	286	302	115	225	255	311	160	154	120	95	130	70	75	46	G _{1/2}	72	12	3	M6x19	M16x1.5	M25x1.5			M6x15	0° /120° /240°	174

EHS-3 双级 安装尺寸 / Two stage mounting dimensions

EHS-3

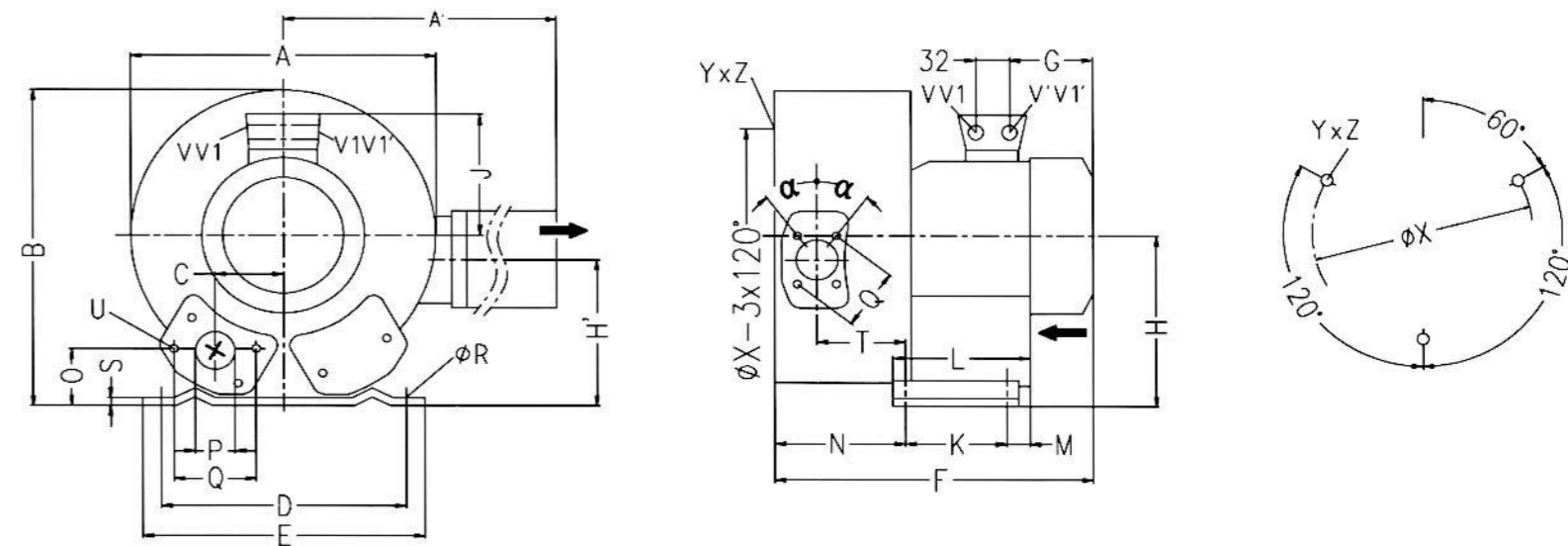

型号 Type	相位	A	A'	B	C	D	E	F	G	H	H'	J	K	L	M	N	O	P	Q	fR	S	T	U	V(1~)	V'(1~)	V1(3~)	V1'(3~)	a	fX	YxZ	X-Holes
EHS-3319	3~	322	324	315	58	225	255	401	191	154	153	128	95	130	73	151	45	G _{1/2}	72	12	3	104	M6x19			M25x1.5	M16x1.5	28°	174	M6x15	51° /171° /291°
EHS-3326	3~	322	324	315	58	225	255	401	191	154	153	128	95	130	73	151	45	G _{1/2}	72	12	3	104	M6x19			M25x1.5	M16x1.5	28°	174	M6x15	51° /171° /291°
EHS-3315A	1~	322	324	315	58	225	255	401	191	154	153	128	95	130	73	151	45	G _{1/2}	72	12	3	104	M6x19	M16x1.5	M25x1.5			28°	174	M6x15	51° /171° /291°

EHS-4/3AC (单、双级) 气环真空泵型号及性能参数表(IP55 50/60HZ)

EHS-4/ 3AC (Single,double impeller) Gas ring vacuum pump models and the performance parameters table (IP55 50/60HZ)

型号 (EHS-4 3AC) Model	单级	频率 frequency HZ	马达额定参数			最大 排吸流量 Max airflow m³/h	额定 真空压力 rated Vacuum mbar	额定 压缩压力 rated compress mbar	噪音 noises db(A)	重量 weight Kg
	双级		功率	电压	电流					
	single double		power KW	voltage V	current A					
EHS-419	单	50	0.85	200-240△ 345-415Y	4.2△/2.3Y	210	-110	100	64	20
		60	0.95	220-275△ 380-480Y	4.0△/2.3Y	255	-80	70	70	
EHS-419-2	单	50	1.3	200-240△ 345-415Y	6.6△/3.8Y	210	-170	170	64	22
		60	1.5	220-275△ 380-480Y	6.9△/4.0Y	255	-150	140	70	
EHS-429	单	50	1.6	200-240△ 345-415Y	7.5△/4.3Y	210	-200	190	64	23
		60	2.05	220-275△ 380-480Y	7.6△/4.4Y	255	-220	210	70	
EHS-439	单	50	2.2	200-240△ 345-415Y	9.7△/5.6Y	210	-220	270	64	26
		60	2.55	220-275△ 380-480Y	10.3△/6.0Y	255	-260	290	70	
EHS-449	单	50	0.85	200-240△ 345-415Y	4.0△/2.3Y	270	-40	40	65	21
		60	0.95	220-275△ 380-480Y	4.2△/2.4Y	330	-40	40	71	
EHS-459	单	50	1.3	200-240△ 345-415Y	6.6△/3.8Y	270	-100	100	65	23
		60	1.5	380-480△ 380-480Y	6.9△/4.0Y	330	-70	50	71	
EHS-469	单	50	1.6	200-240△ 345-415Y	7.5△/4.3Y	270	-150	150	65	24
		60	2.05	380-480△ 380-480Y	7.6△/4.4Y	330	-150	130	71	
EHS-479	单	50	2.2	200-240△ 345-415Y	9.7△/5.6Y	270	-220	230	65	26
		60	2.55	380-480△ 380-480Y	10.3△/6Y	330	-260	210	71	
EHS-4336	双	50	2.2	200-240△ 345-415Y	9.7△/5.6Y	230	-290	360	72	35
		60	2.55	380-480△ 380-480Y	10.3△/6.0Y	275	-350	330	74	
EHS-4337	双	50	3	200-240△ 345-415Y	12.5△/7.2Y	230	-340	410	72	39
		60	3.45	380-480△ 380-480Y	12.6△/7.3Y	275	-380	360	74	
EHS-4346	双	50	4	345-415△ 600-720Y	10△/5.8Y	230	-390	490	72	44
		60	4.6	380-480△ 660-720Y	9.9△/5.71Y	275	-410	480	74	

EHS-4 真空压缩选型曲线 3AC/ Vacuum compression type curve

Vacuum Selection diagram 50 Hz--真空选型图表 50Hz

Compressor Selection Diagram 50 Hz--压缩选型图表 50Hz

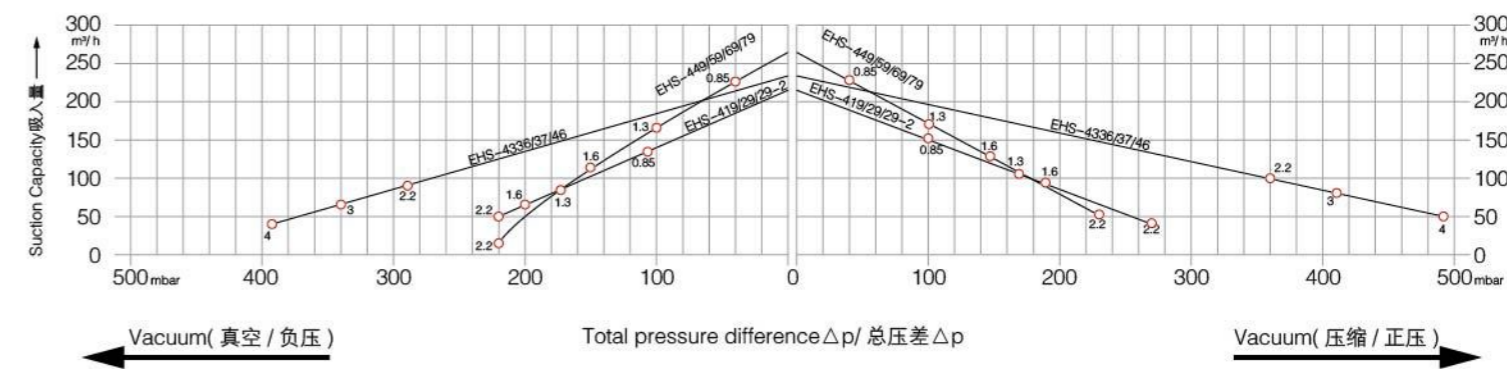

Vacuum Selection diagram 60 Hz--真空选型图表 60Hz

Compressor Selection Diagram 60 Hz--压缩选型图表 60Hz

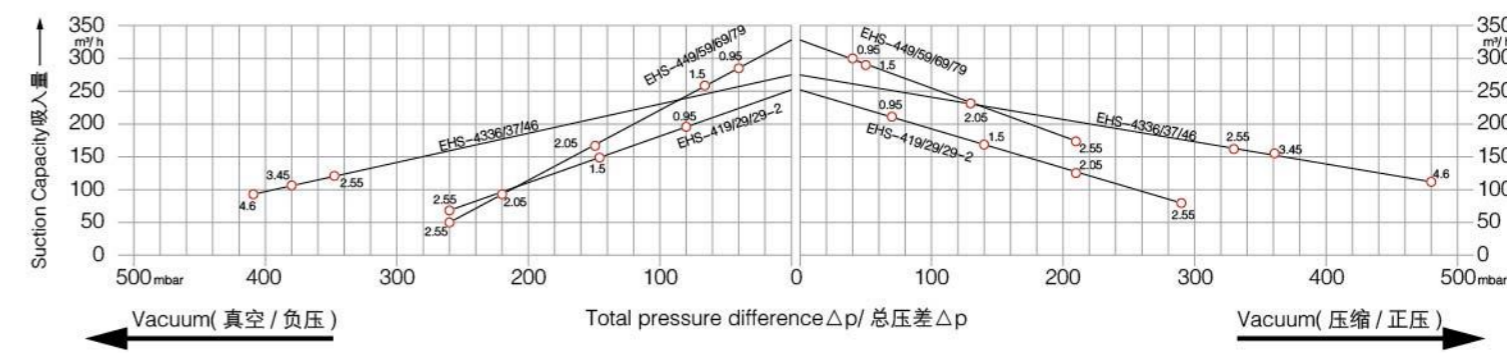

EHS-4 单级 安装尺寸 / Single stage mounting dimensions

EHS-4

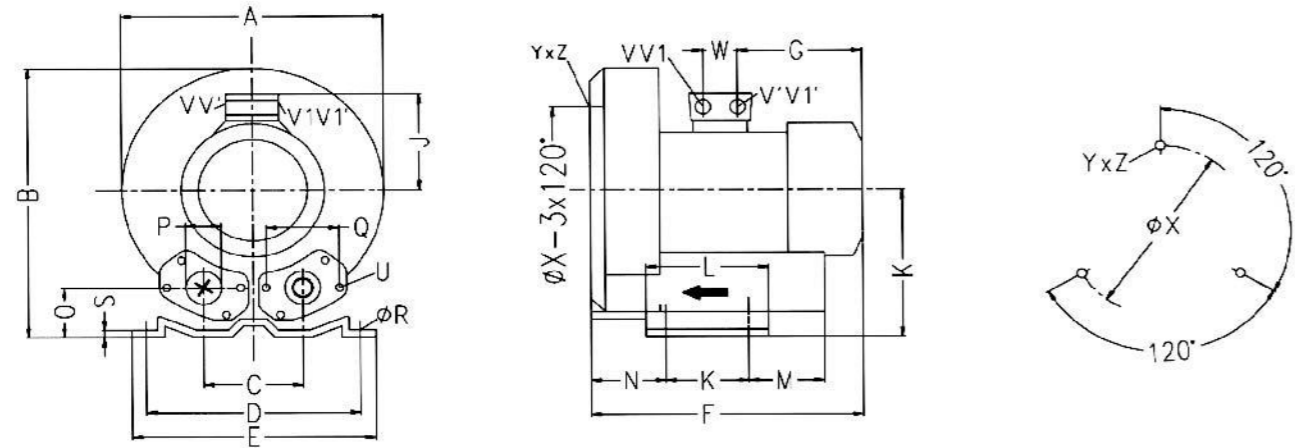

型号 Type	相位	A	B	C	D	E	F	G	H	J	K	L	M	N	O	fP	Q	fR	S	U	V(1~)	V'(1~)	V1(3~)	V1'(3~)	YxZ	X-Holes	fX	W
EHS-419	3~	334	337	120	260	295	314	160	175	120	115	155	96	87	48	55	83	14	4	M8x17			M25x1.5	M16x1.5	M8x20	0° /120° /240°	200	29
EHS-429-2	3~	334	337	120	260	295	314	160	175	120	115	155	96	87	48	55	83	14	4	M8x17			M25x1.5	M16x1.5	M8x20	0° /120° /240°	200	29
EHS-429	3~	334	337	120	260	295	346	191	175	128	115	155	96	87	48	55	83	14	4	M8x17			M25x1.5	M16x1.5	M8x20	0° /120° /240°	200	29
EHS-439	3~	334	337	120	260	295	346	191	175	128	115	155	96	87	48	55	83	14	4	M8x17			M25x1.5	M16x1.5	M8x20	0° /120° /240°	200	29
EHS-449	3~	334	337	120	260	295	334	160	175	120	115	155	96	87	48	55	83	14	4	M8x17			M25x1.5	M16x1.5	M8x20	0° /120° /240°	200	29
EHS-459	3~	334	337	120	260	295	334	160	175	120	115	155	96	87	48	55	83	14	4	M8x17			M25x1.5	M16x1.5	M8x20	0° /120° /240°	200	29
EHS-469	3~	334	337	120	260	295	365	191	175	128	115	155	96	87	48	55	83	14	4	M8x17			M25x1.5	M16x1.5	M8x20	0° /120° /240°	200	29
EHS-479	3~	334	337	120	260	295	365	191	175	128	115	155	96	87	48	55	83	14	4	M8x17			M25x1.5	M16x1.5	M8x20	0° /120° /240°	200	29
EHS-429-2A	1~	334	337	120	260	295	314	160	175	120	115	155	96	87	48	55	83	14	4	M8x17	M16x1.5	M25x1.5			M8x20	0° /120° /240°	200	29
EHS-439A	1~	334	337	120	260	295	345	191	175	128	115	155	96	87	48	55	83	14	4	M8x17	M16x1.5	M25x1.5			M8x20	0° /120° /240°	200	29
EHS-429A	1~	334	337	120	260	295	334	160	175	120	115	155	96	87	48	55	83	14	4	M8x17	M16x1.5	M25x1.5			M8x20	0° /120° /240°	200	29
EHS-449A	1~	334	337	120	260	295	365	191	175	128	115	155	96	87	48	55	83	14	4	M8x17	M16x1.5	M25x1.5			M8x20	0° /120° /240°	200	29

EHS-4 双级 安装尺寸 / Two stage mounting dimensions

EHS-4

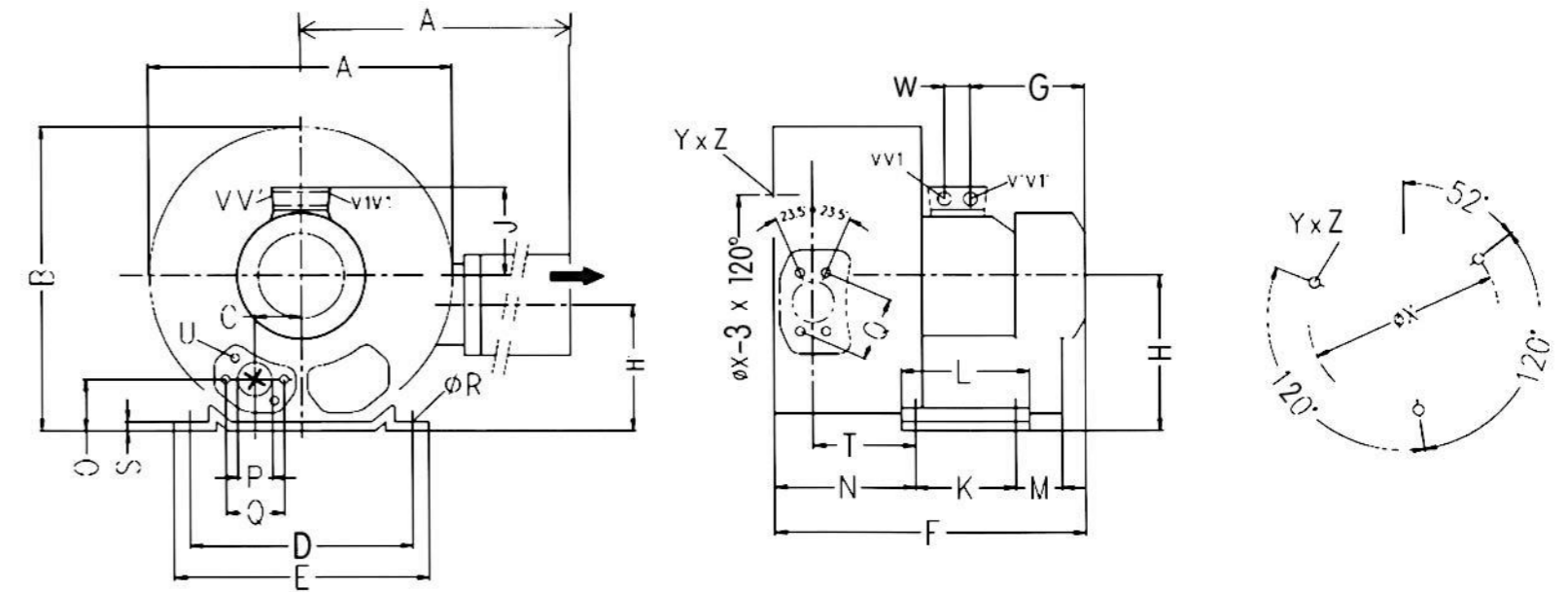

型号 Type	相位	A	A'	B	C	D	E	F	G	H	H'	J	K	L	M	N	O	fP	Q	fR	S	T	U	V	V'	V1	V1'	fX	YxZ	X-Holes	W
EHS-4336	3~	372	411	371	60	260	295	465	190	175	144	135	115	155	98	171	48	55	83	14	4	116	M8x17	M32x1.5	M32x1.5	M32x1.5	M32x1.5	200	M8x20	51.5°/17.5°/291°	42
EHS-4337	3~	372	411	371	60	260	295	465	190	175	144	135	115	155	98	171	48	55	83	14	4	116	M8x17	M32x1.5	M32x1.5	M32x1.5	M32x1.5	200	M8x20	51.5°/17.5°/291°	42
EHS-4346	3~	372	411	371	60	260	295	499	224	175	144	135	115	155	98	171	48	55	83	14	4	116	M8x17	M32x1.5	M32x1.5	M32x1.5	M32x1.5	200	M8x20	51.5°/17.5°/291°	42

EHS-5/3AC (单、双极) 气环真空泵型号及性能参数表(IP55 50/60HZ)

EHS-5/ 3AC (Single,double impeller) Gas ring vacuum pump models and the performance parameters table (IP55 50/60HZ)



型号 (EHS 3AC) Model	单级	马达额定参数				最大 排吸流量 Max airflow m ³ /h	额定 真空压力 rated Vacuum mbar	额定 压缩压力 rated compress mbar	噪音 noises db(A)	重量 weight Kg	
	双级	频率	功率	电压	电流						
	single double	frequency HZ	power KW	voltage V	current A						
EHS-519	单	50	1.6	200-240△	345-415Y	8.5△/4.9Y	265	-170	180	68	25
		60	2.05	220-275△	380-480Y	8.8△/5.1Y	315	-180	190	70	
EHS-539	单	50	2.2	200-240△	345-415Y	9.7△/5.6Y	265	-235	220	69	28
		60	2.55	220-275△	380-480Y	10.3△/6.0Y	315	-245	230	72	
EHS-549	单	50	3	200-240△	345-415Y	12.5△/7.2Y	265	-280	280	69	34
		60	3.45	220-275△	380-480Y	12.5△/7.3Y	315	-260	270	72	
EHS-559	单	50	1.6	200-240△	345-415Y	8.5△/4.9Y	345	-125	125	70	26
		60	2.05	220-275△	380-480Y	8.8△/5.1Y	415	-105	130	73	
EHS-529-9	单	50	2.2	200-240△	345-415Y	9.7△/5.6Y	345	-200	195	70	29
		60	2.55	220-275△	380-480Y	10.3△/6.0Y	415	-170	195	73	
EHS-569	单	50	3	200-240△	345-415Y	12.5△/7.2Y	345	-240	220	70	35
		60	3.45	220-275△	380-480Y	12.6△/7.3Y	415	-210	220	73	

EHS-5 真空压缩选型曲线 3AC/ Vacuum compression type curve

Vacuum Selection diagram 50 Hz--真空选型图表 50Hz

Compressor Selection Diagram 50 Hz--压缩选型图表 50Hz

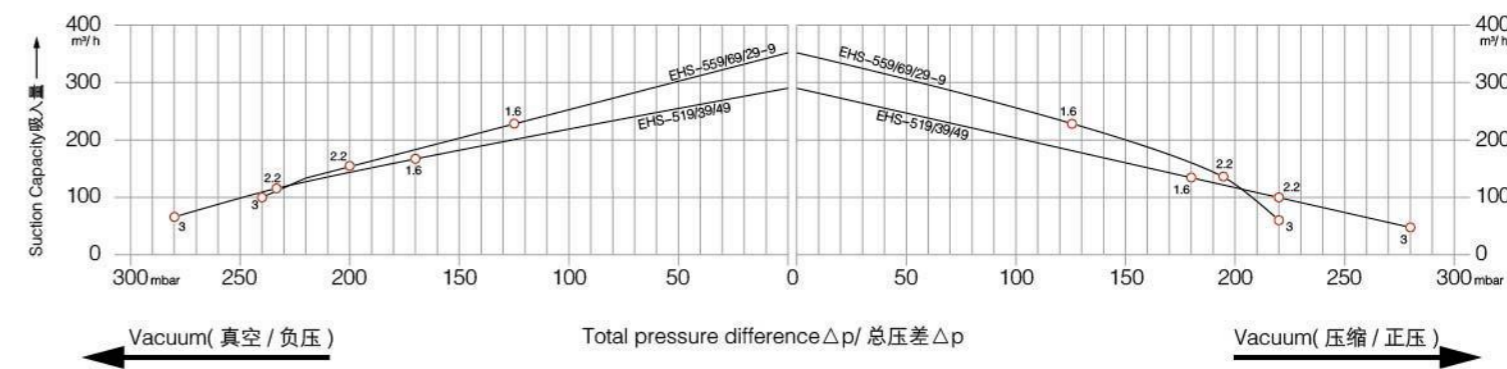

Vacuum Selection diagram 60 Hz--真空选型图表 60Hz

Compressor Selection Diagram 60 Hz--压缩选型图表 60Hz

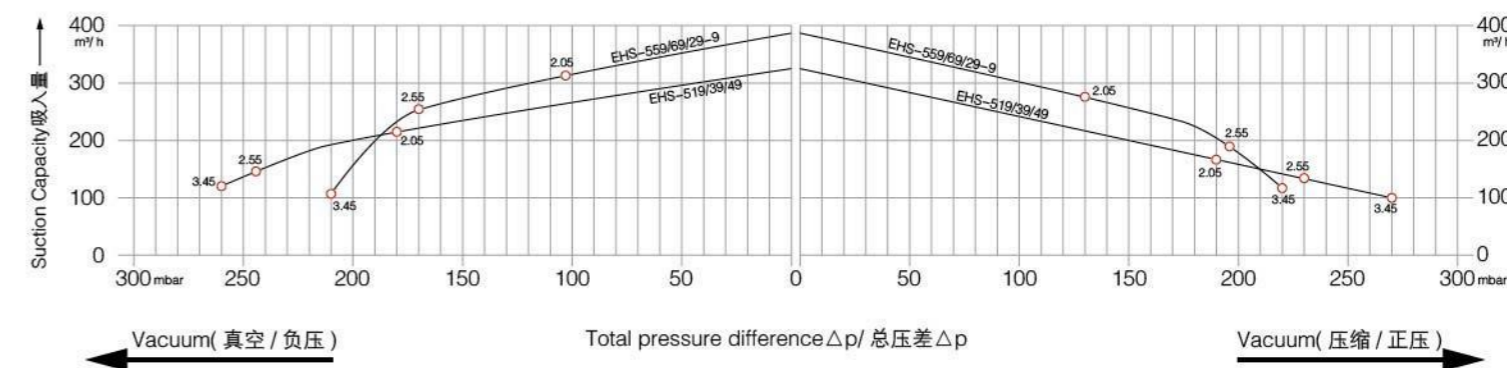

EHS-5 单级安装尺寸/Single stage mounting dimensions

EHS-5

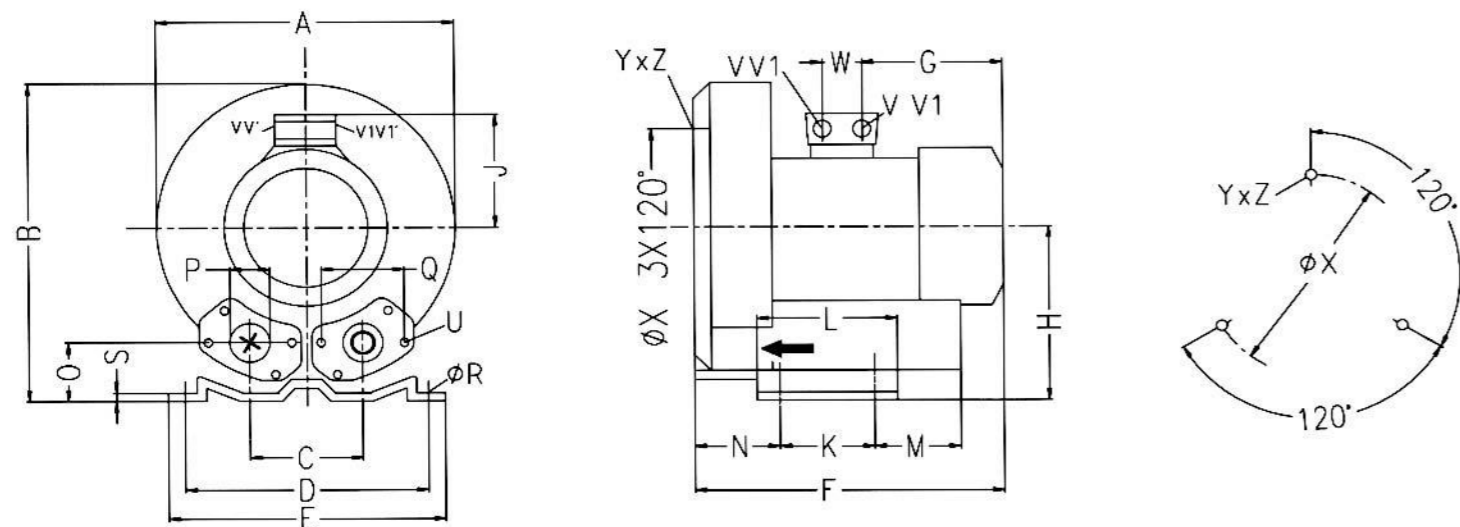

型号 Type	相位	A	B	C	D	E	F	G	H	J	K	L	M	N	O	∠P	∠Q	∠R	S	U	V(1~)	V'(1~)	V1(3~)	V1'(3~)	YxZ	X-Holes	∠X	W
EHS-519	3~	360	366	122	284	325	354	191	192	128	140	180	64	74	56	56	93	13	4.5	M8x17			M25x1.5	M16x1.5	M8x20	0° /120° /240°	226	29
EHS-539	3~	360	366	122	284	325	354	191	192	128	140	180	64	74	56	56	93	13	4.5	M8x17			M25x1.5	M16x1.5	M8x20	0° /120° /240°	226	29
EHS-549	3~	360	366	122	284	325	385	188	192	135	140	180	64	74	56	56	93	13	4.5	M8x17	M32x1.5	M32x1.5		M32x1.5	M8x20	0° /120° /240°	226	42
EHS-559	3~	360	366	122	284	325	372	191	192	128	140	180	64	74	56	56	93	13	4.5	M8x17			M25x1.5	M16x1.5	M8x20	0° /120° /240°	226	29
EHS-529-9	3~	360	366	122	284	325	372	191	192	128	140	180	64	74	56	56	93	13	4.5	M8x17			M25x1.5	M16x1.5	M8x20	0° /120° /240°	226	29
EHS-569	3~	360	366	122	284	325	403	188	192	135	140	180	64	74	56	56	93	13	4.5	M8x17	M32x1.5	M32x1.5		M32x1.5	M8x20	0° /120° /240°	226	42

EHS-6/3AC (单、双级) 气环真空泵型号及性能参数表(IP55 50/60HZ)

EHS-6/ 3AC (Single,double impeller) Gas ring vacuum pump models and the performance parameters table (IP55 50/60HZ)

型号 (EHS 3AC) Model	单级	频率 frequency HZ	功率 power KW	马达额定参数		最大 排吸流量 Max airflow m³/h	额定 真空压力 rated Vacuum mbar	额定 压缩压力 rated compress mbar	噪音 noises db(A)	重量 weight Kg	
	双级			电压	电流						
	single			voltage V	current A						
EHS-529	单	50	2.2	200-240Δ	345-415Y	9.7Δ/5.6Y	318	-210	200	69	31
		60	2.55	220-275Δ	380-480Y	10.3Δ/6.0Y	376	-210	200	72	
EHS-629	单	50	3	200-240Δ	345-415Y	12.5Δ/7.2Y	318	-270	290	69	36
		60	3.45	220-275Δ	380-480Y	12.5Δ/7.3Y	376	-250	230	72	
EHS-639	单	50	4	345-415Δ	600-720Y	9.0Δ/5.5Y	318	-290	390	69	40
		60	4.6	380-480Δ	660-720Y	9.0Δ/5.2Y	376	-330	330	72	
EHS-6326	双	50	2.2	200-240Δ	345-415Y	9.7Δ/5.6Y	320	-220	210	73	43
		60	2.55	220-275Δ	380-480Y	10.3Δ/6.0Y	380	-170	150	76	
EHS-6336	双	50	3	200-240Δ	345-415Y	12.5Δ/7.2Y	320	-280	260	73	48
		60	3.45	220-275Δ	380-480Y	12.6Δ/7.3Y	380	-230	200	76	
EHS-6346	双	50	4.3	345-415Δ	600-720Y	10.4Δ/5.2Y	320	-360	380	73	54
		60	4.8	380-480Δ	660-720Y	10.4Δ/6.0Y	380	-350	320	76	
EHS-6355	双	50	5.5	345-415Δ	600-720Y	13.3Δ/7.7Y	320	-440	500	73	66
		60	6.3	380-480Δ	660-720Y	13.3Δ/7.7Y	380	-440	500	76	
EHS-6375	双	50	7.5	345-415Δ	600-720Y	16.7Δ/9.6Y	320	-440	570	73	74
		60	8.6	380-480Δ	660-720Y	17.3Δ/10.0Y	380	-460	660	76	
EHS-649	单	50	2.2	200-240Δ	345-415Y	9.7Δ/5.6Y	420	-170	170	70	32
		60	2.55	220-275Δ	380-480Y	10.3Δ/6.0Y	500	-160	150	73	
EHS-659	单	50	3	200-240Δ	345-415Y	12.5Δ/7.2Y	420	-220	220	70	37
		60	3.45	220-275Δ	380-480Y	12.6Δ/7.3Y	500	-200	190	73	
EHS-669	单	50	4	345-415Δ	600-720Y	9.0Δ/5.2Y	420	-260	310	70	43
		60	4.6	380-480Δ	660-720Y	9.0Δ/5.2Y	500	-260	280	73	
EHS-6445	双	50	4	345-415Δ	600-720Y	9.0Δ/5.2Y	500	-150	140	74	54
		60	4.6	380-480Δ	660-720Y	9.0Δ/5.2Y	600	-100	90	78	
EHS-6455	双	50	5.5	345-415Δ	600-720Y	13.3Δ/7.7Y	500	-240	260	74	69
		60	6.3	380-480Δ	660-720Y	13.3Δ/7.7Y	600	-210	200	78	
EHS-6475	双	50	7.5	345-415Δ	600-720Y	16.7Δ/9.6Y	500	-240	320	74	75
		60	8.6	380-480Δ	660-720Y	17.3Δ/10.0Y	600	-270	300	78	

EHS-6 真空压缩选型曲线 3AC/ Vacuum compression type curve

Vacuum Selection diagram 50 Hz--真空选型图表 50Hz

Compressor Selection Diagram 50 Hz--压缩选型图表 50Hz

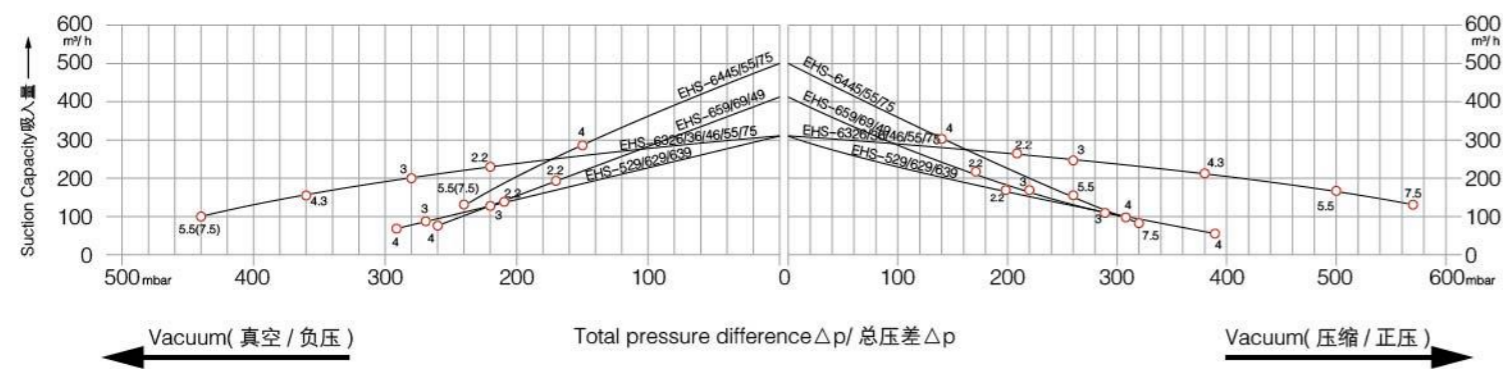

Vacuum Selection diagram 60 Hz--真空选型图表 60Hz

Compressor Selection Diagram 60 Hz--压缩选型图表 60Hz

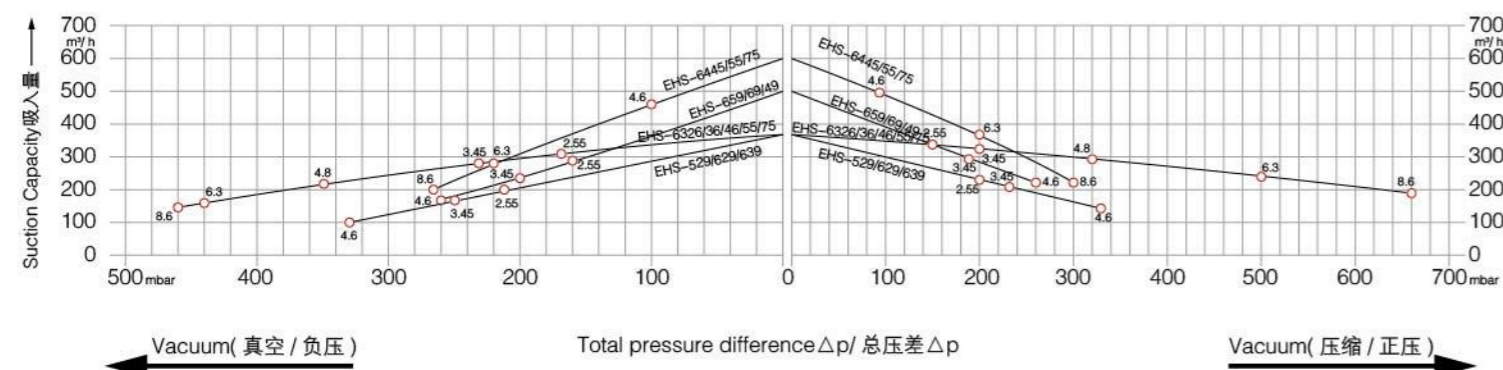

EHS-6 单级安装尺寸/Single stage mounting dimensions

EHS-6

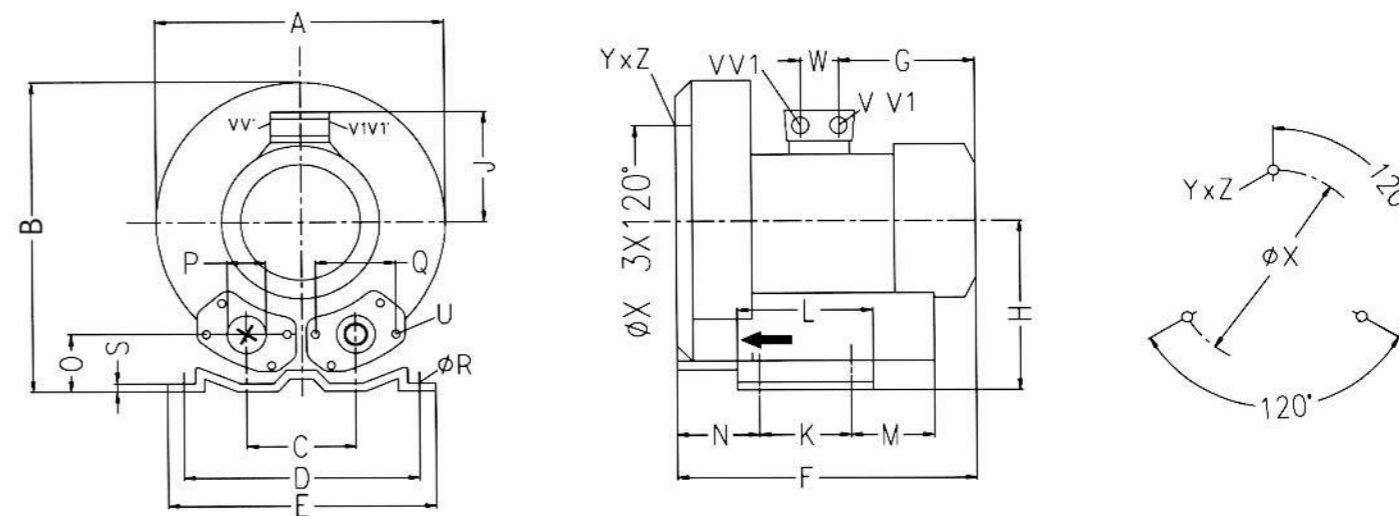

型号 Type	相位	A	B	C	D	E	F	G	H	J	K	L	M	N	O	fP	Q	fR	S	U	V(1~)	V'(1~)	V1(3~)	V1'(3~)	YxZ	X-Holes	f X	W
EHS-529	3~	382	384	125	290	325	377	191	197	128	140	180	84	109	54	55	83	15	4.5	M8x17			M32x1.5		M10x20	0° /120° /240°	240	29
EHS-629	3~	382	384	125	290	325	409	188	197	135	140	180	84	109	54	55	83	15	4.5	M8x17	M32x1.5	M32x1.5	M25x1.5	M32x1.5	M10x20	0° /120° /240°	240	42
EHS-639	3~	382	384	125	290	325	432	209	197	148	140	180	84	109	54	55	83	15	4.5	M8x17	M32x1.5	M32x1.5	M25x1.5	M32x1.5	M10x20	0° /120° /240°	240	42
EHS-649	3~	382	384	125	290	325	387	191	197	128	140	180	84	109	54	55	83	15	4.5	M8x17	M32x1.5	M32x1.5	M25x1.5		M10x20	0° /120° /240°	240	29
EHS-659	3~	382	384	125	290	325	419	189	197	135	140	180	84	109	54	55	83	15	4.5	M8x17	M32x1.5	M32x1.5	M25x1.5		M10x20	0° /120° /240°	240	42
EHS-669	3~	382	384	125	290	325	440	209	197	148	140	180	84	109	54	55	83	15	4.5	M8x17	M32x1.5	M32x1.5	M25x1.5	M32x1.5	M10x20	0° /120° /240°	240	42
EHS-629A	1~	382	384	125	290	325	377	191	197	128	140	180	84	109	54	55	83	15	4.5	M8x17			M25x1.5	M16x1.5	M10x20	0° /120° /240°	240	29

EHS-6 双级安装尺寸 / Two stage mounting dimensions

EHS-6

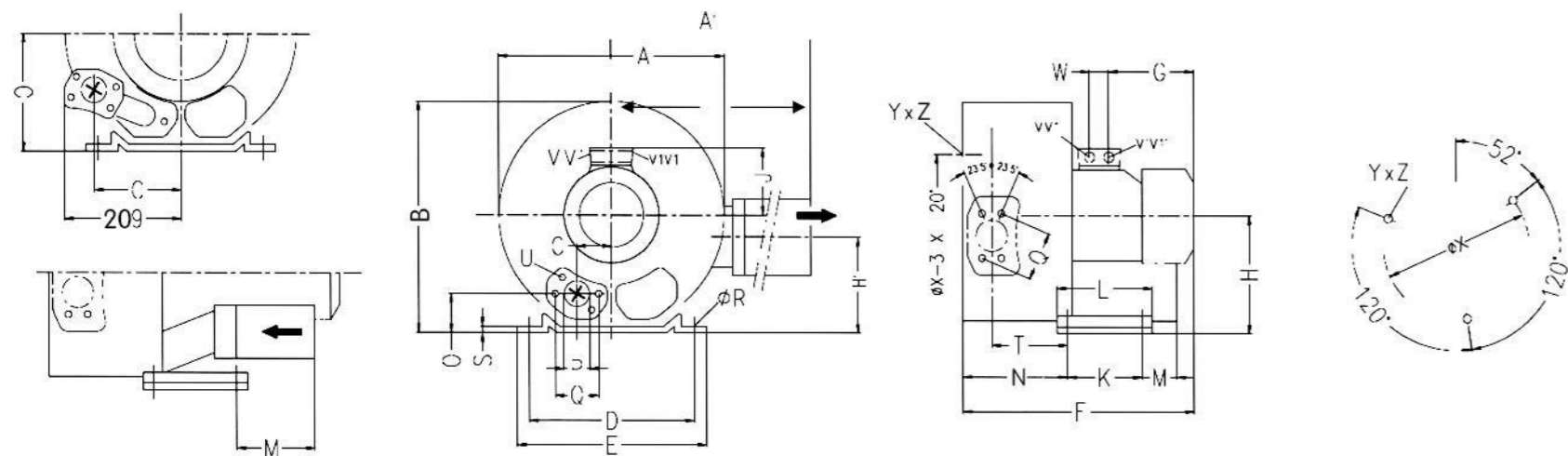

型号 Type	相位	A	A'	B	C	D	E	F	G	H	H'	J	K	L	M	N	O	fP	Q	fR	S	T	U	V	V'	V1	V1'	fX	YxZ	X-Holes	W
EHS-6326	3~	426	426	410	63	290	325	473	191	197	162	128	140	180	84	205	53	55	83	15	4.5	130	M8x17	M25x1.5	M16x1.5	M32x1.5	M32x1.5	240	M10x20	51.5°/171.5°/291.5°	29
EHS-6336	3~	426	426	410	63	290	325	496	188	197	162	135	140	180	84	205	53	55	83	15	4.5	130	M8x17	M25x1.5	M32x1.5	M32x1.5	M32x1.5	240	M10x20	51.5°/171.5°/291.5°	42
EHS-6346	3~	426	426	410	63	290	325	526	209	197	162	148	140	180	84	205	53	55	83	15	4.5	130	M8x17	M25x1.5	M32x1.5	M32x1.5	M32x1.5	240	M10x20	51.5°/171.5°/291.5°	42
EHS-6355	3~	426	426	410	154	290	325	571	226	197	162	167	140	180	200	205	53	55	83	15	4.5	130	M8x17	M25x1.5	M32x1.5	M32x1.5	M32x1.5	240	M10x20	51.5°/171.5°/291.5°	42
EHS-6375	3~	426	426	410	154	290	325	571	226	197	162	167	140	180	200	205	53	55	83	15	4.5	130	M8x17	M25x1.5	M32x1.5	M32x1.5	M32x1.5	240	M10x20	51.5°/171.5°/291.5°	42

EHS-6 双级安装尺寸 / Two stage mounting dimensions

EHS-6

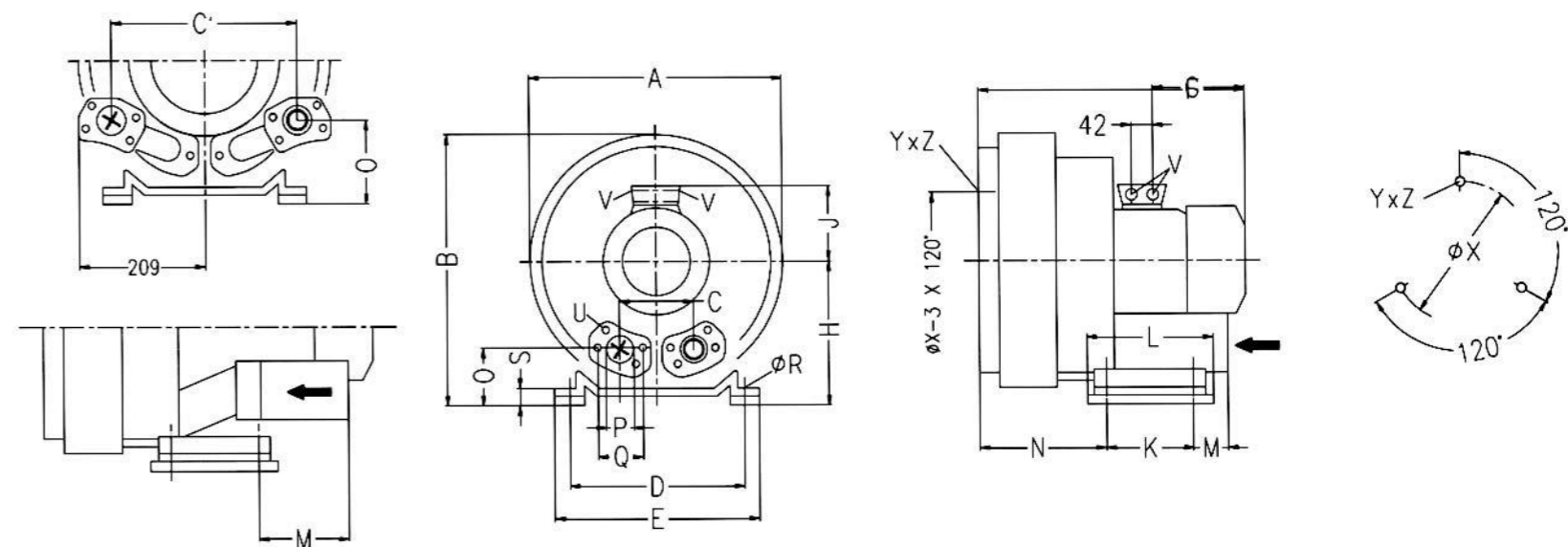

型号 Type	相位	A	B	C	C'	D	E	F	G	H	J	K	L	M	N	O	fP	Q	fR	S	U	V	fX	YxZ	X-Holes
EHS-6445	3~	420	469	125	/	290	325	526	209	197	148	140	180	84	205	153	55	83	15	64.5	M8x17	4xM32x1.5	240	M10x20	0° /120° /240°
EHS-6455	3~	420	469	/	308	290	325	571	226	257	167	140	180	200	205	153	55	83	15	64.5	M8x17	4xM32x1.5	240	M10x20	0° /120° /240°
EHS-6475	3~	420	469	/	308	290	325	571	226	257	167	140	180	200	205	153	55	83	15	64.5	M8x17	4xM32x1.5	240	M10x20	0° /120° /240°

EHS-6/3AC (单、三级) 气环真空泵型号及性能参数表(IP55 50/60HZ)

新增产品

EHS-6/3AC (Single,three impeller) Gas ring vacuum pump models and the performance parameters table (IP55 50/60HZ)

New products

型号 (EHS /3AC) double	单级	马达额定参数				最大 排吸流量 Max airflow m³/h	额定 真空压力 rated Vacuum mbar	额定 压缩压力 rated compress mbar	噪音 noises db(A)	重量 weight Kg
	双级	频率	功率	电压	电流					
	single double	frequency HZ	power KW	voltage V	current A					
EHS-679	单	50	3	200-240Δ 345-415Y	12.5Δ/7.2Y	540	-180	170	81	47
		60	3.45	220-275Δ 380-480Y	12.6Δ/7.3Y	635	-120	130	83	
EHS-689	单	50	4.3	345-415Δ 600-720Y	11Δ/6.5Y	540	-210	200	83	50
		60	4.8	380-480Δ 660-720Y	12.5Δ/7.2Y	635	-150	140	85	

EHS-6

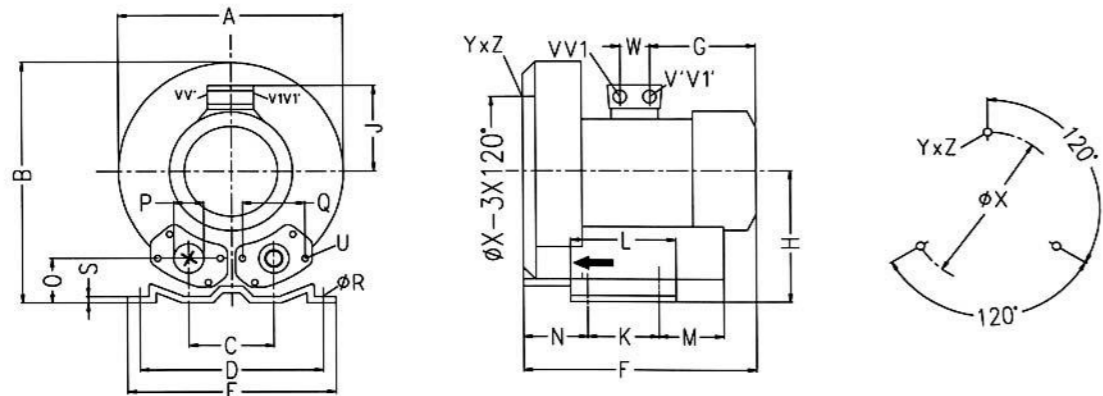

型号 Type	相位	A	B	C	D	E	F	G	H	J	K	L	M	N	O	fP	Q	fR	S	U	V	fX	YxZ	X-Holes
EHS-679	3~	426	447	145	305	332	437	230	243	148	155	235	128	129	45	G2 _{1/2}	79	12	6	M8x17	M32x1.5	262	M12x20	0° /120° /240°
EHS-689	3~	426	447	145	305	332	467	230	243	148	155	235	128	129	45	G2 _{1/2}	79	12	6	M8x17	M32x1.5	262	M12x20	0° /120° /240°

EHS-7/8/3AC (单、双级) 气环真空泵型号及性能参数表(IP55 50/60HZ)

EHS-7/8/ 3AC (Single,double impeller) Gas ring vacuum pump models and the performance parameters table (IP55 50/60HZ)

型号 (EHS 3AC) double	单级	马达额定参数				最大 排吸流量 Max airflow m³/h	额定 真空压力 rated Vacuum mbar	额定 压缩压力 rated compress mbar	噪音 noises db(A)	重量 weight Kg
	双级	频率	功率	电压	电流					
	single double	frequency HZ	power KW	voltage V	current A					
EHS-719	单	50	4.0	345-415Δ 600-720Y	9.5Δ/5.5Y	530	-200	200	70	54
		60	4.6	380-480Δ 660-720Y	9.5Δ/5.5Y	620	-160	160	74	
EHS-729	单	50	5.5	345-415Δ 600-720Y	12.9Δ/7.4Y	530	-300	300	70	63
		60	6.3	380-480Δ 660-720Y	12.9Δ/7.45Y	620	-320	280	74	
EHS-829	单	50	7.5	345-415Δ 600-720Y	16.7Δ/9.6Y	530	-320	430	70	66
		60	8.6	380-480Δ 660-720Y	17.3Δ/10.0Y	620	-350	400	74	
EHS-8309	双	50	5.5	345-415Δ 600-720Y	13.3Δ/7.7Y	520	-240	240	74	83
		60	6.3	380-480Δ 660-720Y	13.3Δ/7.7Y	620	-170	160	78	
EHS-8310	双	50	7.5	345-415Δ 600-720Y	16.7Δ/9.6Y	520	-400	400	74	86
		60	8.6	380-480Δ 660-720Y	17.3Δ/10.0Y	620	-360	330	78	
EHS-8315	双	50	11.0	345-415Δ 600-720Y	28.0Δ/16.2Y	520	-430	600	74	104
		60	12.6	380-480Δ 660-720Y	29.0Δ/16.7Y	620	-460	600	78	
EHS-8316	双	50	15	345-415Δ 600-720Y	32.5Δ/18.8Y	520	-460	670	74	120
		60	17.3	380-480Δ 660-720Y	34.5Δ/19.9Y	620	-490	750	78	
EHS-839	单	50	4.0	345-415Δ 600-720Y	9.5Δ/5.5Y	700	-150	140	70	57
		60	4.6	380-480Δ 660-720Y	9.5Δ/5.5Y	840	-90	90	74	
EHS-849	单	50	5.5	345-415Δ 600-720Y	12.9Δ/7.4Y	700	-200	180	70	66
		60	6.3	380-480Δ 660-720Y	12.9Δ/7.45Y	840	-180	180	74	
EHS-859	单	50	7.5	345-415Δ 600-720Y	16.7Δ/9.6Y	700	-270	260	70	69
		60	8.6	380-480Δ 660-720Y	17.3Δ/10.0Y	840	-270	260	74	
EHS-8410	双	50	7.5	345-415Δ 600-720Y	16.7Δ/9.6Y	900	-200	180	74	91
		60	8.6	380-480Δ 660-720Y	17.3Δ/10.0Y	1050	-150	120	78	
EHS-8415	双	50	11.0	345-415Δ 600-720Y	28.0Δ/16.2Y	900	-280	370	74	110
		60	12.6	380-480Δ 660-720Y	29.0Δ/16.7Y	1050	-310	350	78	
EHS-8416	双	50	15	345-415Δ 600-720Y	32.5Δ/18.8Y	900	-300	390	74	126
		60	17.5	380-480Δ 660-720Y	34.5Δ/19.9Y	1050	-330	370	78	

EHS-7/8 真空压缩选型曲线 3AC/ Vacuum compression type curve

Vacuum Selection diagram 50 Hz--真空选型图表 50Hz

Compressor Selection Diagram 50 Hz--压缩选型图表 50Hz

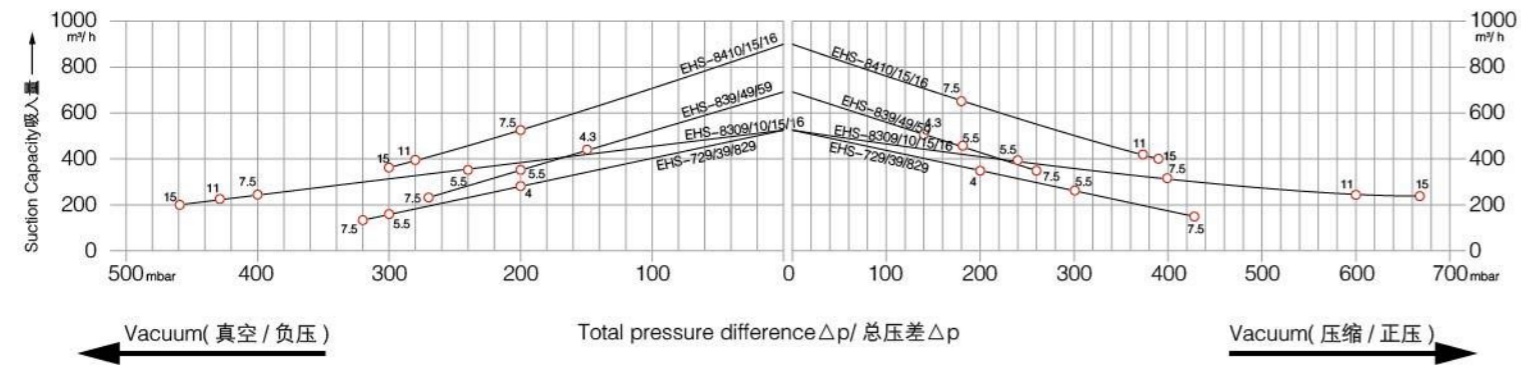

Vacuum Selection diagram 60 Hz--真空选型图表 60Hz

Compressor Selection Diagram 60 Hz--压缩选型图表 60Hz

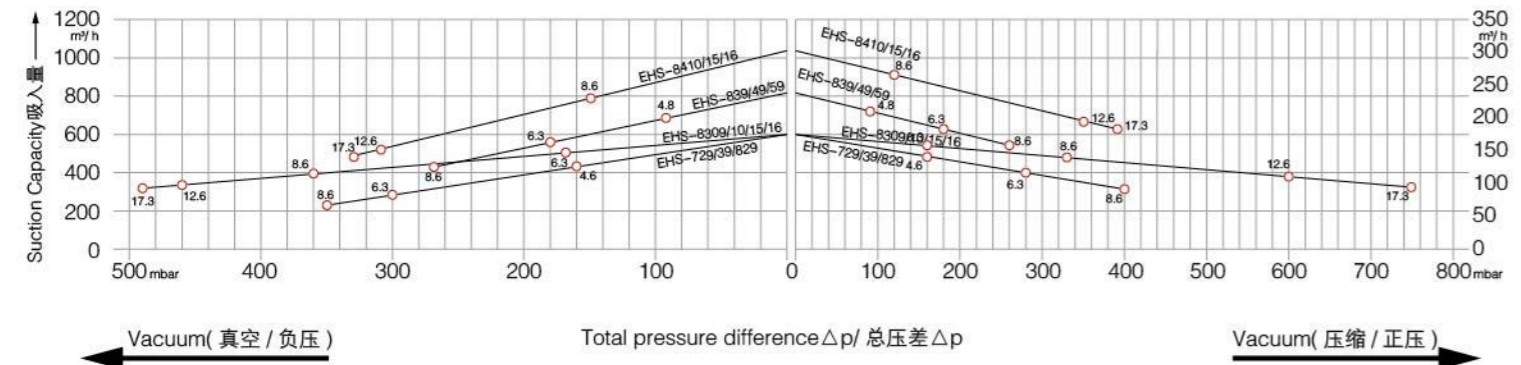

EHS-8 单级 安装尺寸 / Single stage mounting dimensions

EHS-8

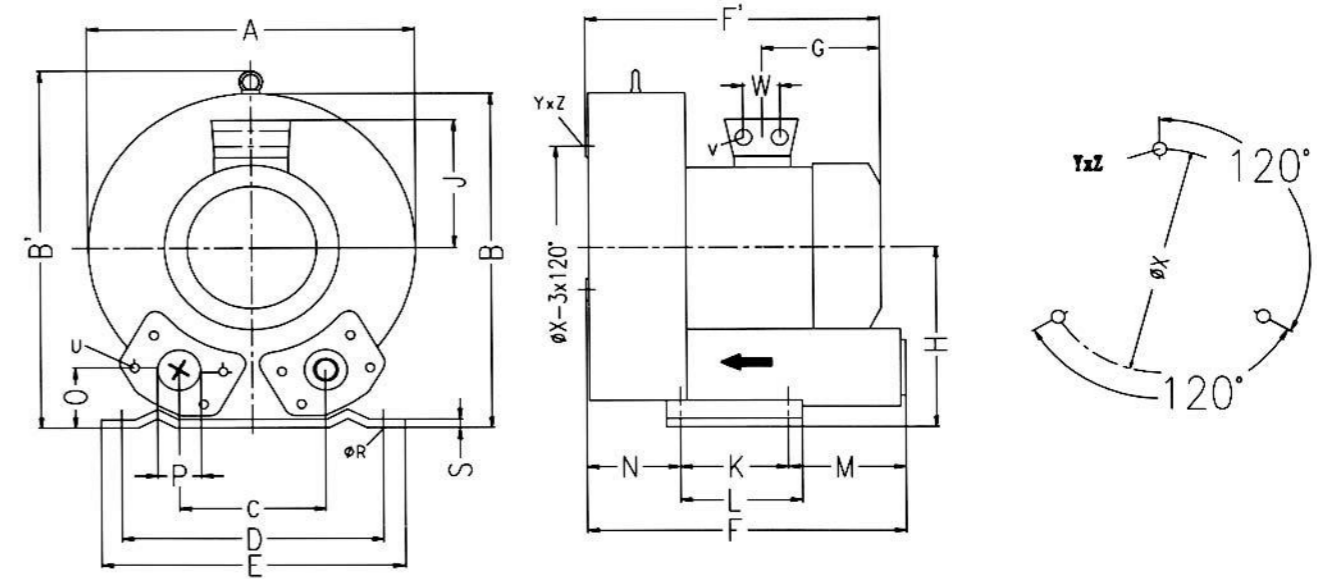

型号 Type	相位	A	A'	B	B'	C	D	E	F	F'	G	H	H'	J	K	L	M	N	N'	O	φP	φR	S	V	W	φX	YxZ	X-Holes
EHS-719	3~	451		461	509	152	356	394	433	450	230	240		148	170	217	140	124		65	G2 _{1/2}	15	6	4xM32x1.5	42	286	M12x20	0° /120° /240°
EHS-729	3~	451		461	509	152	356	394	433	477	226	240		167	170	217	140	124		65	G2 _{1/2}	15	6	4xM32x1.5	42	286	M12x20	0° /120° /240°
EHS-829	3~	451		461	509	152	356	394	433	447	226	240		167	170	217	140	124		65	G2 _{1/2}	15	6	4xM32x1.5	42	286	M12x20	0° /120° /240°
EHS-839	3~	451		509	509	152	356	394	449	466	230	240		148	170	217	139	164		65	G2 _{1/2}	15	6	4xM32x1.5	42	286	M12x20	0° /120° /240°
EHS-849	3~	451		509	509	152	356	394	449	492	247	240		167	170	217	139	164		65	G2 _{1/2}	15	6	4xM32x1.5	42	286	M12x20	0° /120° /240°
EHS-859	3~	451		461	509	152	356	394	449	492	247	240		167	170	217	139	164		65	G2 _{1/2}	15	6	4xM32x1.5	42	286	M12x20	0° /120° /240°

EHS-8 双级安装尺寸 / Two stage mounting dimensions

EHS-8

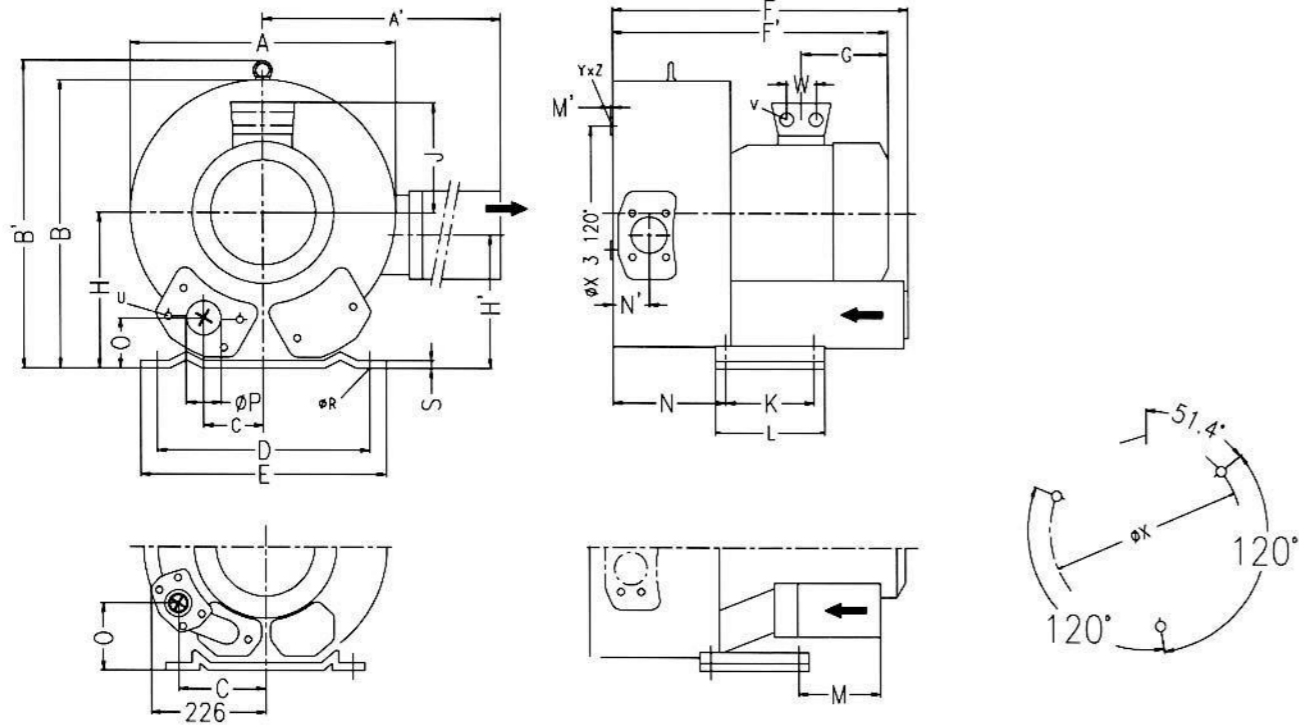

型号 Type	相位	A	A'	B	B'	C	D	E	F	F'	G	H	H'	J	K	L	M	N	N'	O	fP	fR	S	V	W	fX	YxZ	X-Holes
EHS-8309	3~	500	549	509	509	76	356	394	545	589	226	240	199	167	170	217	236	84	65	G _{2 1/2}	15	6	4xM32x1.5	42	286	M12x20	51.4°/120°/240°	
EHS-8310	3~	500	549	509	509	76	356	394	545	589	226	240	199	167	170	217	236	84	65	G _{2 1/2}	15	6	4xM32x1.5	42	286	M12x20	51.4°/120°/240°	
EHS-8315	3~	500	549	509	509	76	356	394	694	717	318	240	199	197	170	217	212	84	105	G _{2 1/2}	15	6	4xM40x1.5	54	286	M12x20	51.4°/120°/240°	
EHS-8316	3~	500	549	509	509	76	356	394	694	717	318	240	199	197	170	217	212	84	105	G _{2 1/2}	15	6	4xM40x1.5	54	286	M12x20	51.4°/120°/240°	

EHS-8 双级安装尺寸 / Two stage mounting dimensions

EHS-8

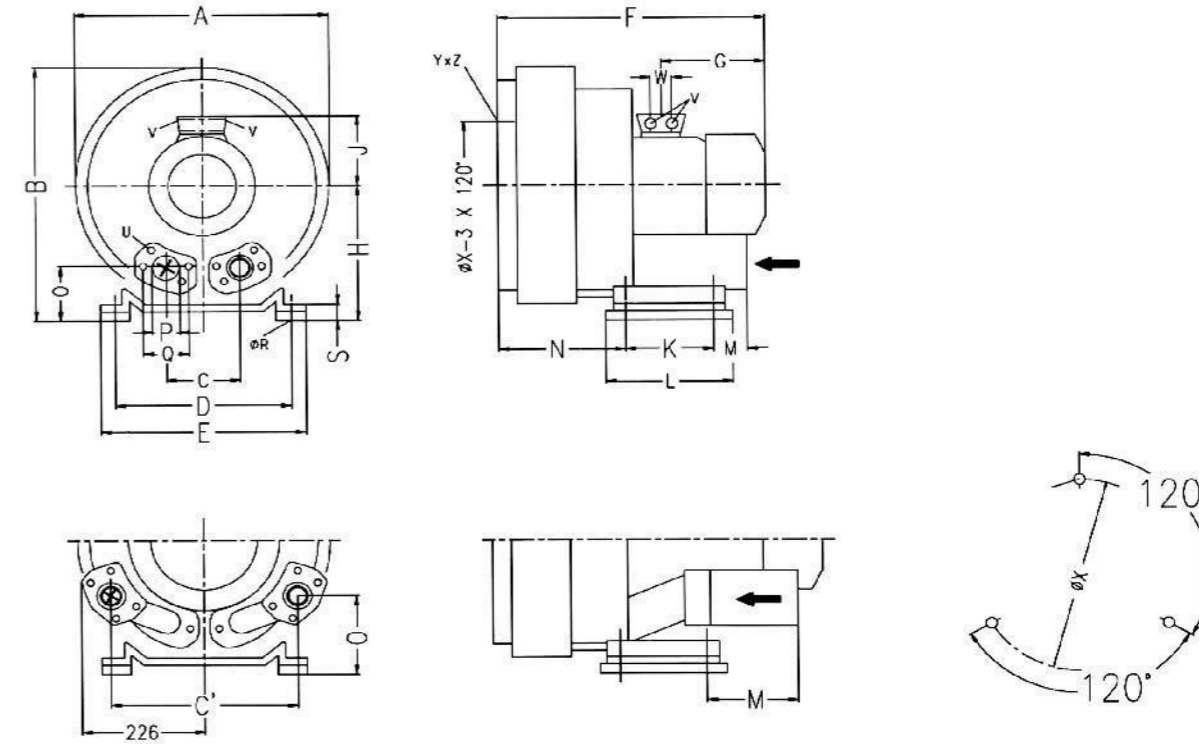

型号 Type	相位	A	B	C	C'	D	E	F	G	H	J	K	L	M	N	O	fP	fR	S	V	W	fX	YxZ	X-Holes
EHS-8410	3~	500	550	152		356	394	589	247	300	167	170	217	236	125	G _{2 1/2}	15	66	4xM32x1.5	42	286	M12x20	0°/120°/240°	
EHS-8415	3~	500	550		336	356	394	694	318	300	197	170	217	312	212	165	G _{2 1/2}	15	66	4xM40x1.5	54	286	M12x20	0°/120°/240°
EHS-8416	3~	500	550		336	356	394	694	318	300	197	170	217	312	212	165	G _{2 1/2}	15	66	4xM40x1.5	54	286	M12x20	0°/120°/240°

EHS-9/3AC (单、双级) 气环真空泵型号及性能参数表(IP55 50/60HZ)

EHS-9/ 3AC (Single,double impeller) Gas ring vacuum pump models and the performance parameters table (IP55 50/60HZ)

型号 (EHS 3AC) Model	单级	马达额定参数				最大 排吸流量 Max airflow m ³ /h	额定 真空压力 rated Vacuum mbar	额定 压缩压力 rated compress mbar	噪音 noises db(A)	重量 weight Kg	
	双级	频率	功率	电压	电流						
	single double	frequency HZ	power KW	voltage V	current A						
EHS-919	单	50	8.5	345-415Δ	600-720Y	18.2Δ/10.5Y	1050	-210	210	74	93
		60	9.8	380-480Δ	660-720Y	18.2Δ/10.5Y	1250	-180	180	79	
EHS-929	单	50	12.5	345-415Δ	600-720Y	28.0Δ/16.2Y	1050	-280	270	74	116
		60	14.5	380-480Δ	660-720Y	29.0Δ/16.7Y	1250	-270	260	79	
EHS-930	单	50	15	345-415Δ	600-720Y	35.0Δ/20.0Y	1050	-320	380	74	120
		60	17.5	380-480Δ	660-720Y	36.5Δ/21.0Y	1250	-340	360	79	
EHS-939	单	50	18.5	345-415Δ	600-720Y	37.0Δ/21.0Y	1050	-340	460	74	128
		60	21.3	380-480Δ	660-720Y	39.0Δ/22.5Y	1250	-380	420	79	
EHS-9320	双	50	12.5	345-415Δ	600-720Y	28.0Δ/16.2Y	1110	-300	270	74	187
		60	14.5	380-480Δ	660-720Y	29.0Δ/16.7Y	1310	-220	200	78	
EHS-9322	双	50	16.5	345-415Δ	600-720Y	35.0Δ/20.0Y	1110	-420	370	74	197
		60	19	380-480Δ	660-720Y	36.5Δ/21.0Y	1310	-340	300	84	
EHS-9325	双	50	20	345-415Δ	600-720Y	40.0Δ/23.0Y	1110	-440	500	74	204
		60	23	380-480Δ	660-720Y	42.0Δ/24.2Y	1310	-440	430	84	
EHS-9326	双	50	25	345-415Δ	600-720Y	52.0Δ/30.0Y	1110	-440	590	74	211
		60	29	380-480Δ	660-720Y	52.0Δ/30.0Y	1310	-440	540	84	
EHS-949	单	50	8.5	345-415Δ	600-720Y	18.2Δ/10.5Y	1370	-120	110	75	98
		60	9.8	380-480Δ	660-720Y	18.2Δ/10.5Y	1650	-80	70	80	
EHS-959	单	50	12.5	345-415Δ	600-720Y	28.0Δ/16.2Y	1370	-210	190	75	121
		60	14.5	380-480Δ	660-720Y	29.0Δ/22.5Y	1650	-170	160	80	
EHS-969	单	50	18.5	345-415Δ	600-720Y	37.0Δ/21.0Y	1370	-310	320	75	131
		60	21.3	380-480Δ	660-720Y	39.0Δ/22.5Y	1650	-300	280	80	
EHS-9410	双	50	15	345-415Δ	600-720Y	35.0Δ/20.0Y	1940	-130	120	75	187
		60	17.5	380-480Δ	660-720Y	36.5Δ/21.0Y	2310	-60	40	84	
EHS-9415	双	50	20	345-415Δ	600-720Y	40.0Δ/23.0Y	1940	-220	200	75	212
		60	23	380-480Δ	660-720Y	42.0Δ/24.2Y	2310	-160	130	84	
EHS-9418	双	50	25	345-415Δ	600-720Y	52.0Δ/30.0Y	1940	-310	280	75	219
		60	29	380-480Δ	660-720Y	52.0Δ/30.0Y	2310	-270	220	84	
EHS-9420	双	50	15	345-415Δ	600-720Y	35.0Δ/20.0Y	2050	-160	170	75	220
		60	17.5	380-480Δ	660-720Y	36.5Δ/21.0Y	2480	-110	120	84	
EHS-9425	双	50	20	345-415Δ	600-720Y	40.0Δ/23.0Y	2050	-250	230	75	230
		60	23	380-480Δ	660-720Y	42.0Δ/24.2Y	2480	-190	180	84	
EHS-9426	双	50	25	345-415Δ	600-720Y	52.0Δ/30.0Y	2050	-310	280	75	235
		60	29	380-480Δ	660-720Y	52.0Δ/30.0Y	2480	-280	230	84	

EHS-9 真空压缩选型曲线 3AC/ Vacuum compression type curve

Vacuum Selection diagram 50 Hz--真空选型图表 50Hz

Compressor Selection Diagram 50 Hz--压缩选型图表 50Hz

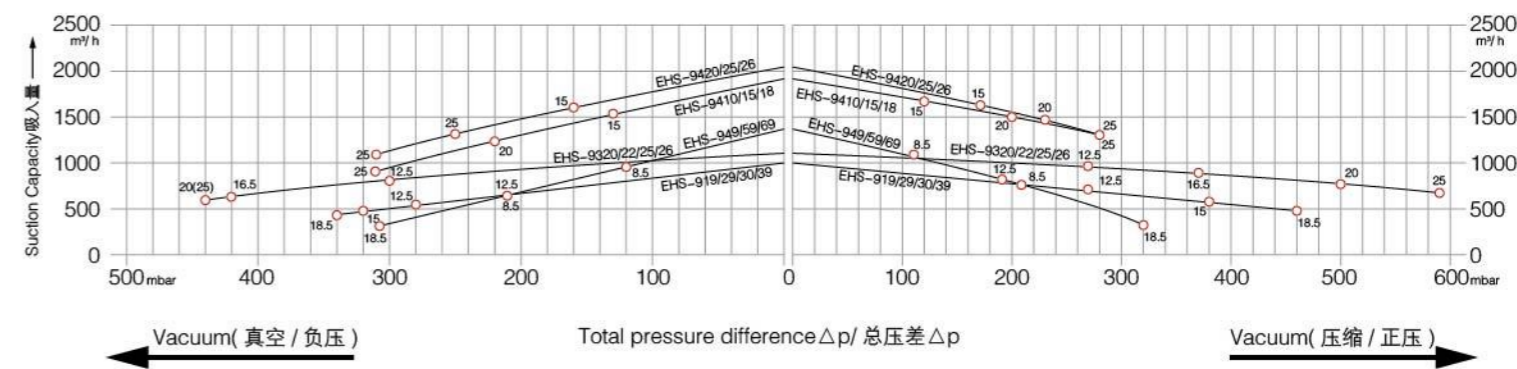

Vacuum Selection diagram 60 Hz--真空选型图表 60Hz

Compressor Selection Diagram 60 Hz--压缩选型图表 60Hz

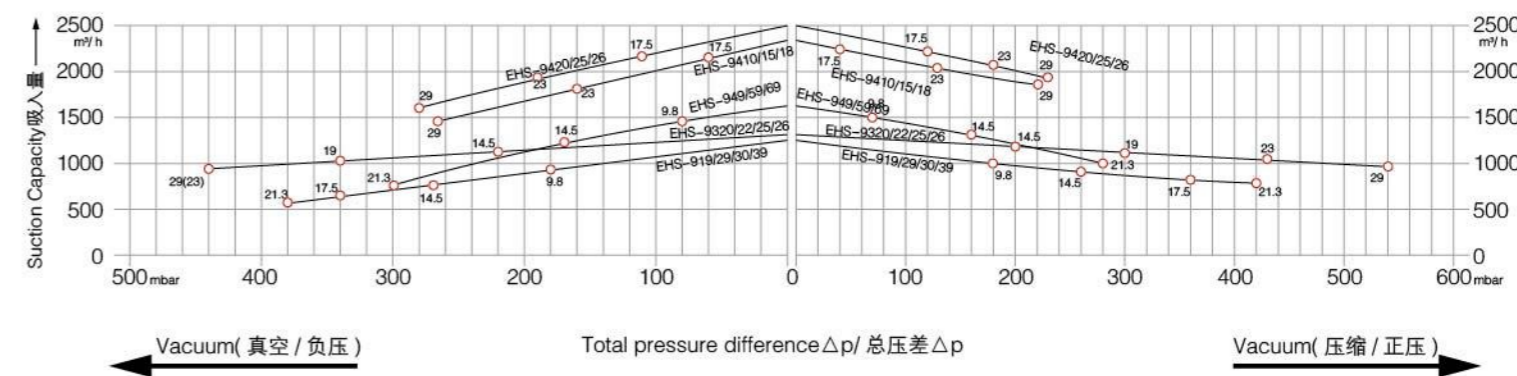

EHS-9 单级 安装尺寸 / Single stage mounting dimensions

EHS-9

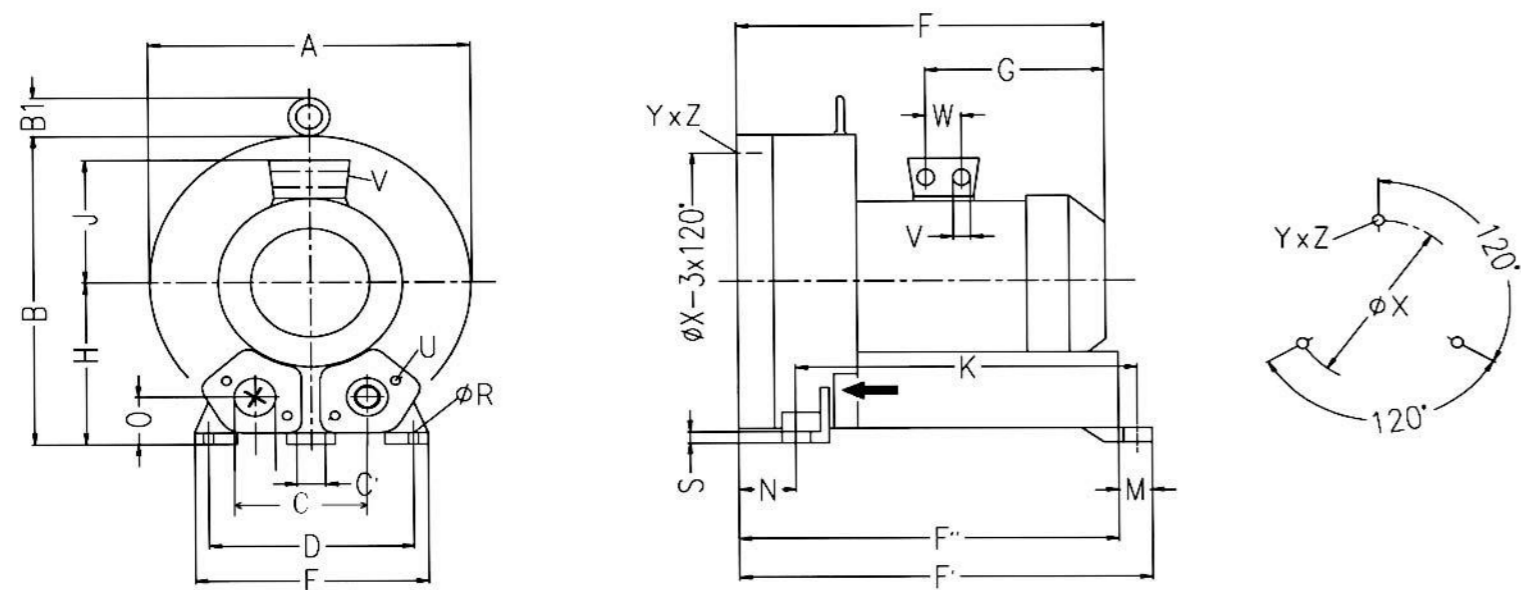

型号 Type	相位	A	B	B1	C	C'	D	E	F	F'	F''	G	H	J	K	M	N	O	φP	φQ	φR	S	U	V	W	φX	YxZ	X-Holes
EHS-919	3~	550	569	55	207	15	360	415	525	644	605	268	300	167	533	39	89	92	100	150	15	21	M12x30	4xM32x1.5	42	490	M12x20	0° /120° /240°
EHS-929	3~	550	569	55	207	15	360	415	611	644	605	345	300	197	533	39	89	92	100	150	15	21	M12x30	4xM32x1.5	54	490	M12x20	0° /120° /240°
EHS-930	3~	550	569	55	207	15	360	415	611	644	605	345	300	197	533	39	89	92	100	150	15	21	M12x30	4xM32x1.5	54	490	M12x20	0° /120° /240°
EHS-939	3~	550	569	55	207	15	360	415	611	644	605	345	300	197	533	39	89	92	100	150	15	21	M12x30	4xM32x1.5	54	490	M12x20	0° /120° /240°
EHS-949	3~	550	569	55	207	15	360	415	563	682	643	268	300	167	533	39	127	92	100	150	15	21	M12x30	4xM32x1.5	42	490	M12x20	0° /120° /240°
EHS-959	3~	550	569	55	207	15	360	415	649	682	643	345	300	197	533	39	127	92	100	150	15	21	M12x30	4xM32x1.5	54	490	M12x20	0° /120° /240°
EHS-969	3~	550	569	55	207	15	360	415	649	682	643	345	300	197	533	39	127	92	100	150	15	21	M12x30	4xM32x1.5	54	490	M12x20	0° /120° /240°

EHS-9 双级 安装尺寸 / Two stage mounting dimensions

EHS-9

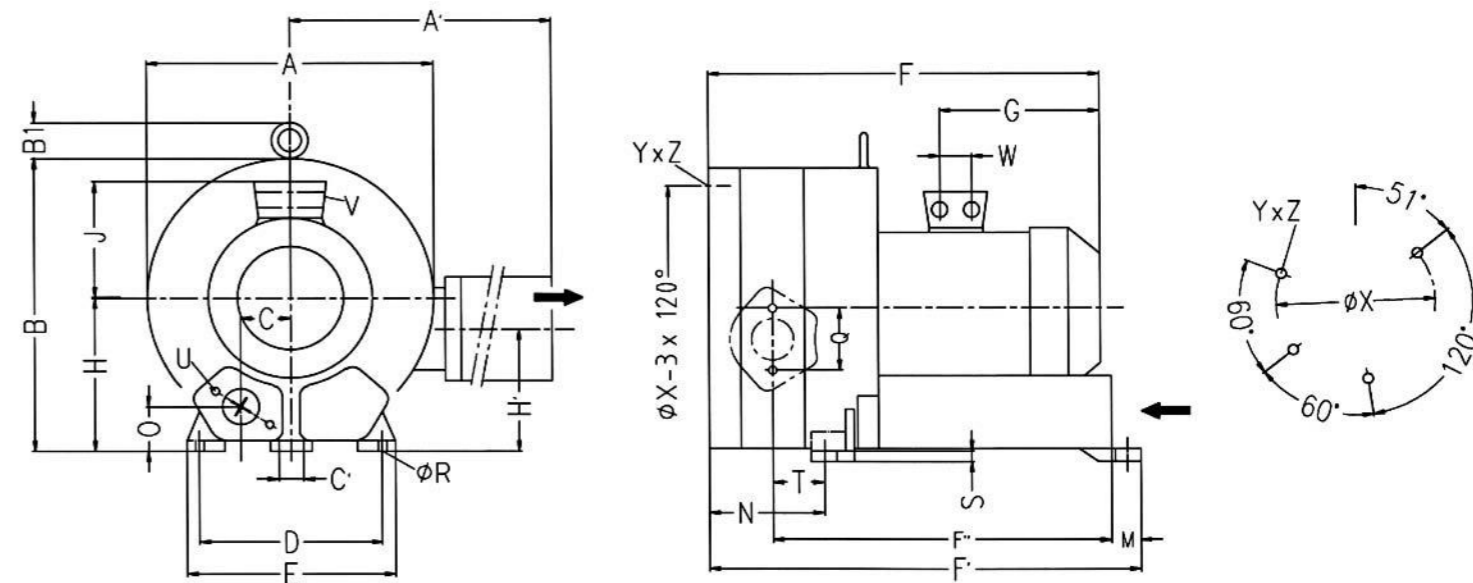

型号 Type	相位	A	A'	B	B1	C	C'	D	E	F	F'	F''	G	H	H'	J	K	M	N	O	φP	φQ	φR	S	T	U	V	W	φX	YxZ	X-Holes
EHS-9320	3~	615	780	607	16	103.5	15	360	415	752	786	634	345	300	234	197	533	39	230	92	100	150	15	21	117	M12x30	4xM40x1.5	54	490	M12x30	51.4°/120°/240°
EHS-9322	3~	615	780	607	16	103.5	15	360	415	752	786	634	345	300	234	197	533	39	230	92	100	150	15	21	117	M12x30	4xM40x1.5	54	490	M12x30	51.4°/120°/240°
EHS-9325	3~	615	780	607	16	103.5	15	360	415	752	786	634	345	300	234	197	533	39	230	92	100	150	15	21	117	M12x30	4xM40x1.5	54	490	M12x30	51.4°/120°/240°
EHS-9326	3~	615	780	607	16	103.5	15	360	415	812	786	634	405	300	234	197	533	39	230	92	100	150	15	21	117	M12x30	4xM40x1.5	54	490	M12x30	51.4°/120°/240°

EHS-9 双级 安装尺寸 Two stage mounting dimensions

EHS-9

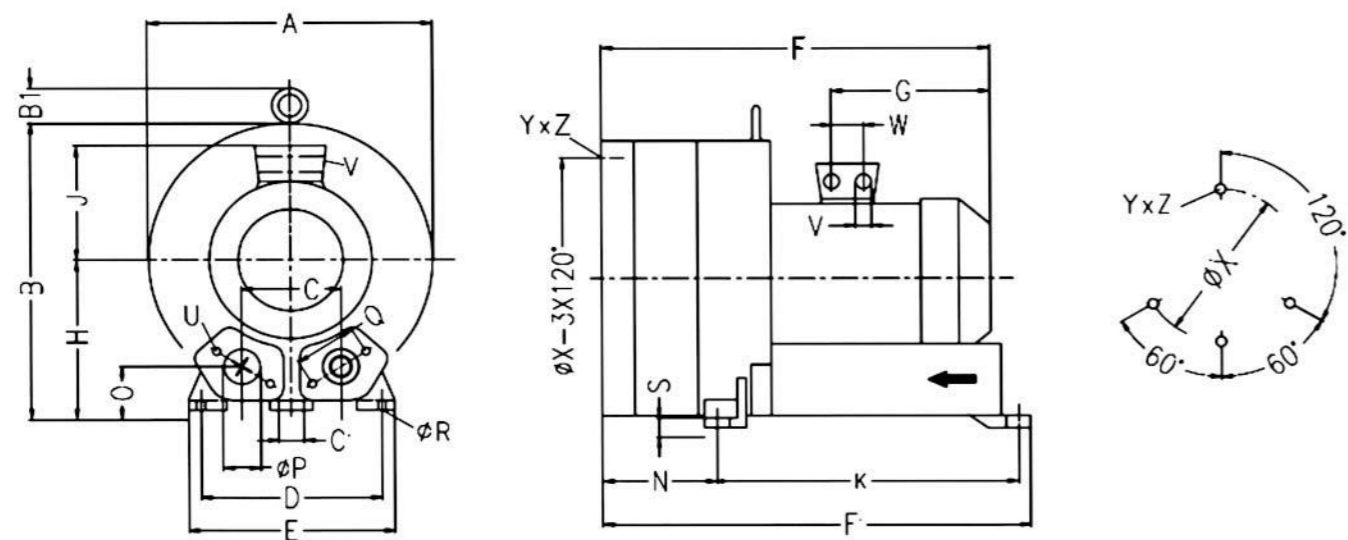

型号 Type	相位	A	B	B1	C	C'	D	E	F	F'	G	H	J	K	M	N	O	φP	Q	φR	S	U	V	W	φX	YxZ	X-Holes
EHS-9410	3~	615	657	16	207	15	360	415	752	786	345	350	197	533	39	280	142	100	140	15	71	M12x35	4xM40x1.5	54	490	M12x30	120° /60° /60°
EHS-9415	3~	615	657	16	207	15	360	415	752	786	345	350	197	533	39	280	142	100	140	15	71	M12x35	4xM40x1.5	54	490	M12x30	120° /60° /60°
EHS-9418	3~	615	657	16	207	15	360	415	812	786	345	350	197	533	39	280	142	100	140	15	71	M12x35	4xM40x1.5	54	490	M12x30	120° /60° /60°

EHS-9 双级 安装尺寸 Two stage mounting dimensions

EHS-9

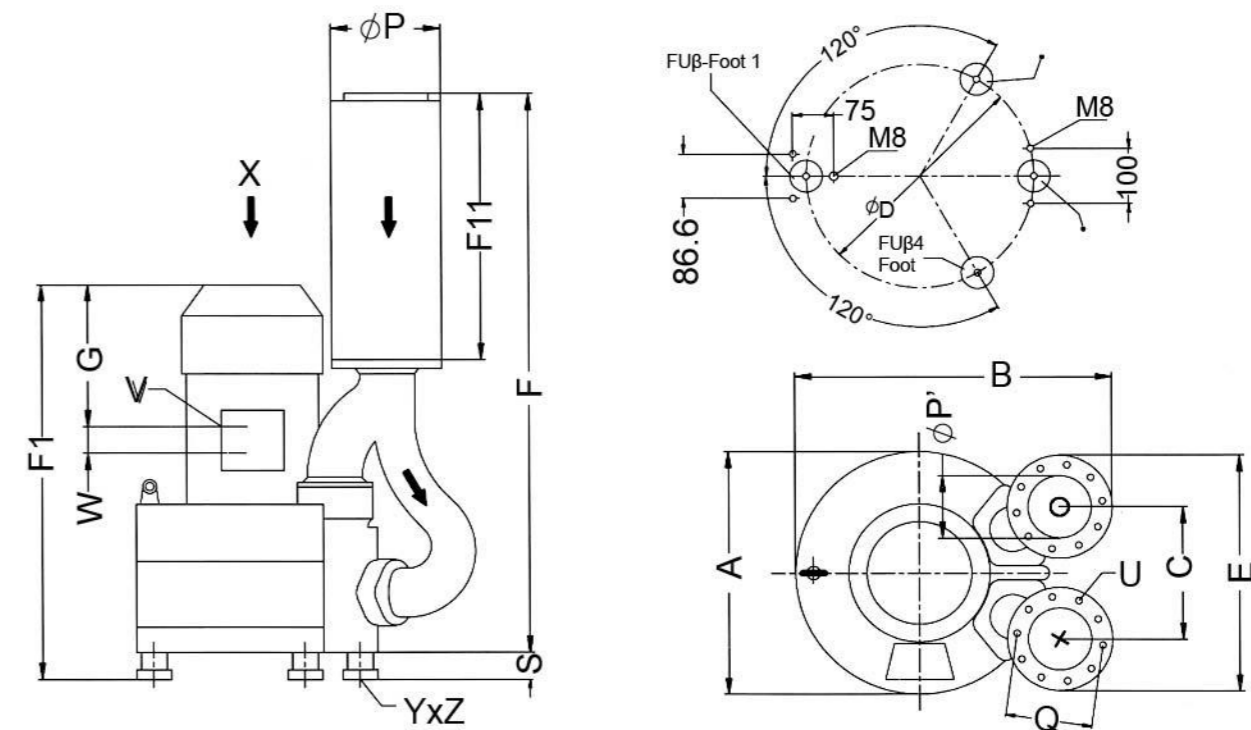

型号 Type	相位	A	B	C	D	E	F	F'	F''	G	P	P'	Q	S	U	V	W	YxZ
EHS-9420	3~	615	723	307	490	526	1201	848	578	291	219	135	201	58	M8x40	4 x M40x1.5	54	M12x10.5
EHS-9425	3~	615	723	307	490	526	1201	848	578	291	219	135	201	58	M8x40	4 x M40x1.5	54	M12x10.5
EHS-9426	3~	615	723	307	490	526	1201	908	578	351	219	135	201	58	M8x40	4 x M40x1.5	54	M12x10.5

EHS2/1AC(单级)气环真空泵型号及性能参数表(IP55 50/60HZ)

EHS2/1AC(Single impeller) Gas ring vacuum pump models and the performance parameters table(IP55 50/60HZ)

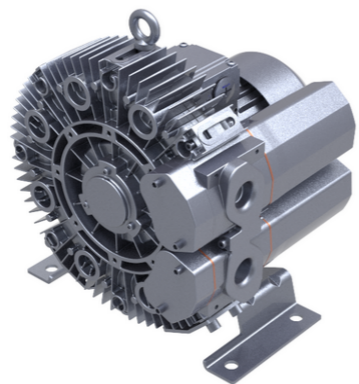

型号 (EHS2)	单 双 级	频率 HZ	额定 功率 KW	额定电压 V	额定 电流 A	最大 排吸流量 m³/h	额定 真空压力 mbar	额定 压缩压力 mbar	噪音 dB(A)	重量 Kg
EHS2-239A	双	50	1.5	200-240V	9.7	47	-370	600	58	30
		60	1.75	200-240v	10.3	60	-420	660	62	
EHS2-249A	单	50	0.94	200-240V	7.6	66	-250	350	57	18
		60	1.1	200-240V	9	80	-280	390	62	
EHS2-259A	双	50	1.5	200-240V	9.7	65	-400	550	59	32
		60	1.75	200-240V	10.3	76	-390	540	53	
EHS-319A	单	50	1.1	200-240V	10.1	87	-300	380	55	23
		60	1.3	200-240V	10.3	105	-350	390	62	

EHS2-1AC 单级 真空压缩选型曲线 Vacuum compression type curve

Vacuum Selection diagram 50 Hz—真空选型图表 50 Hz

Compressor Celetion Diagram 50 Hz—压缩选型图表 50 Hz

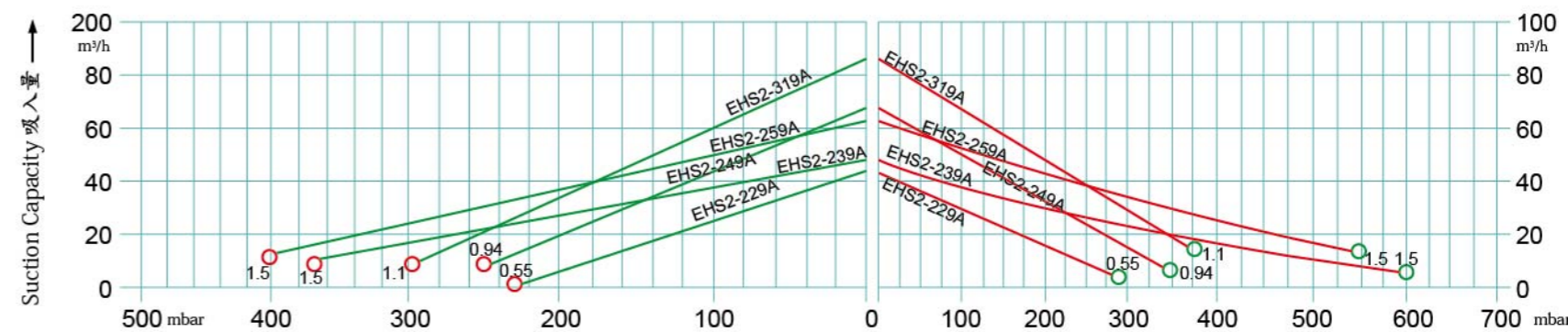

Vacuum Selection diagram 60 Hz—真空选型图表 60 Hz

Compressor Celetion Diagram 60 Hz—压缩选型图表 60 Hz

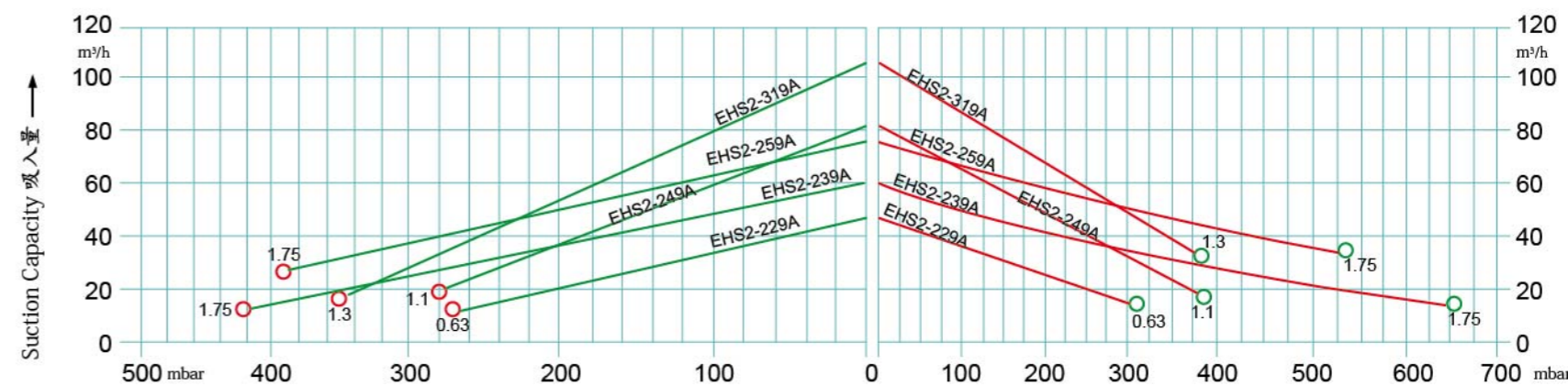

EHS2/3AC(单级)气环真空泵型号及性能参数表(IP55 50/60HZ)

EHS2/3AC(Single impeller) Gas ring vacuum pump models and the performance parameters table(IP55 50/60HZ)

型号 (EHS2/3AC) Model	单级	频率 frequency HZ	马达额定参数			最大 排吸流量 Max airflow m ³ /h	额定 真空压力 rated Vacuum mbar	额定 压缩压力 rated compress mbar	噪音 noises db(A)	重量 weight Kg
	双级		功率	电压	电流					
	single double		power KW	voltage V	current A					
EHS2-229	单	50	0.55	200-240△ 345-415Y	2.8△/1.6Y	47	-230	290	57	16
		60	0.63	220-275△ 380-480Y	3△/1.7Y	57	-270	320	62	
EHS2-239	单	50	0.55	200-240△ 345-415Y	2.8△/1.6Y	66	-250	250	57	16
		60	0.63	220-275△ 380-480Y	3△/1.7Y	80	-260	250	62	
EHS2-249	单	50	0.85	200-240△ 345-415Y	4△/2.3Y	66	-280	350	57	17
		60	0.95	220-275△ 380-480Y	4△/2.3Y	80	-340	360	62	
EHS2-319	单	50	1.1	200-240△ 345-415Y	5.4△/3.1Y	87	-300	380	58	23
		60	1.3	220-275△ 380-480Y	5.4△/3.1Y	105	-340	370	62	
EHS2-329	单	50	1.6	200-240△ 345-415Y	7.5△/4.3Y	120	-310	360	64	26
		60	2.05	220-275△ 380-480Y	7.6△/4.4Y	145	-340	320	68	
EHS2-339	单	50	2.2	200-240△ 345-415Y	11.4△/6.6Y	120	-310	470	64	29
		60	2.55	220-275△ 380-480Y	11.2△/6.5Y	145	-360	480	68	
EHS2-349	单	50	2.2	200-240△ 345-415Y	11.4△/6.6Y	165	-340	360	65	32
		60	2.55	220-275△ 380-480Y	11.2△/6.5Y	195	-360	320	71	
EHS2-359	单	50	3.3	200-240△ 345-415Y	13△/7.5Y	165	-340	480	65	35
		60	3.8	220-275△ 380-480Y	14.2△/8.2Y	195	-380	530	71	

EHS2-3AC 单级 真空压缩选型曲线 Vacuum compression type curve

Vacuum Selection diagram 50 Hz—真空选型图表 50 Hz

Compressor Celetion Diagram 50 Hz—压缩选型图表 50 Hz

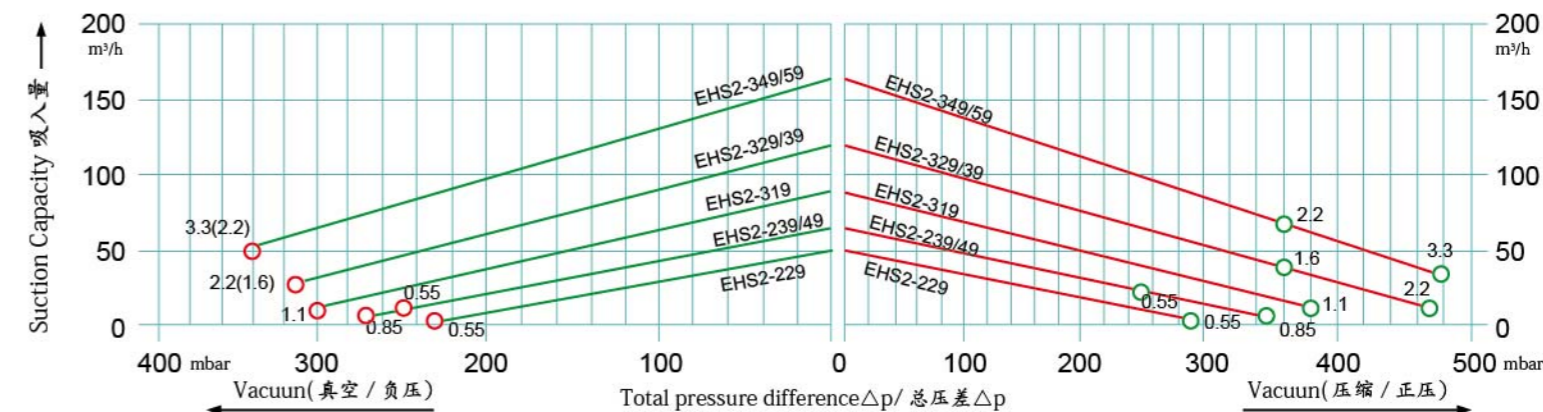

Vacuum Selection diagram 60 Hz—真空选型图表 60 Hz

Compressor Celetion Diagram 60 Hz—压缩选型图表 60 Hz

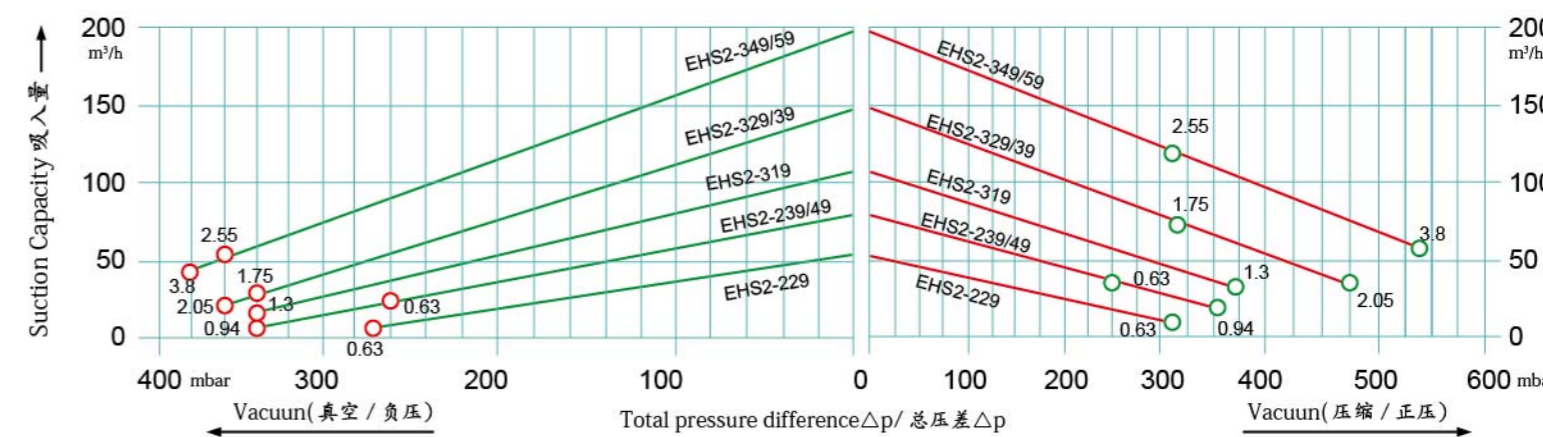

EHS2 单级 安装尺寸 Single stage mounting dimensions

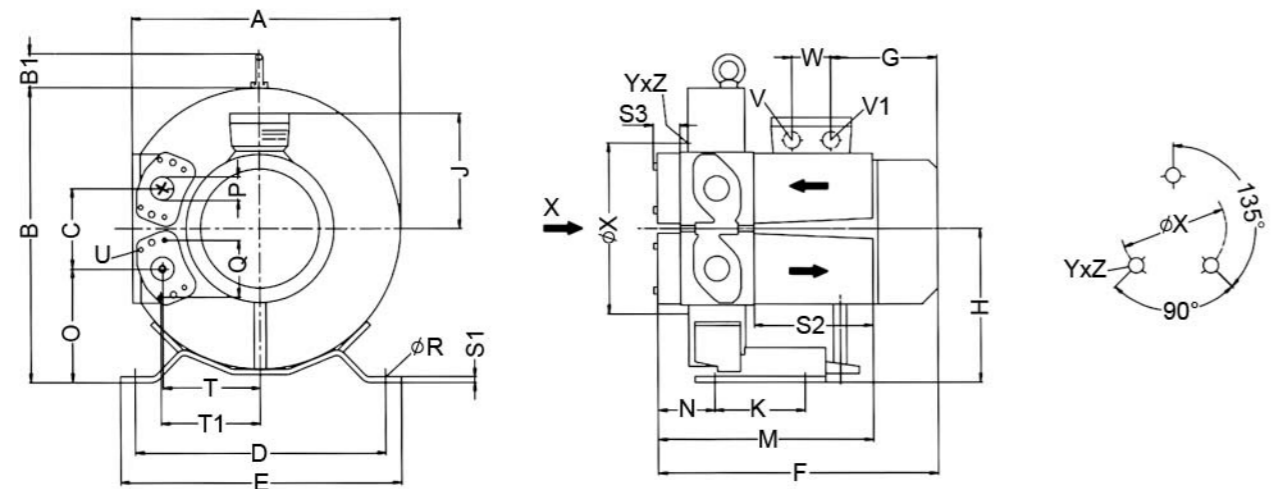

型号 Type	相位	A	B	B1	C	D	E	F	G	H	J	K	M	N	O	P	Q	R	S1	S2	S3	T	T1	U	V	V	W	X	YxZ
EHS2-229	3~	294	319	39	87	260	298	293	129	167	111	105	252	65	124	G11/4	64	14	4	140	31	105	107	M6x17	M25x1.5	M16x1.5	32	153	M6x15
EHS2-239	3~	313	339	39	94	290	325	295	153	177	120	105	256	67	130	G11/4	64	14	4	140	31	114	116	M6x17	M25x1.5	M16x1.5	32	153	M6x15
EHS2-249	3~	313	339	39	94	290	325	295	153	177	120	105	256	67	130	G11/4	64	14	4	140	31	114	116	M6x17	M25x1.5	M16x1.5	32	153	M6x15
EHS2-319	3~	346	375	39	103	315	350	321	129	195	111	130	260	66	143	G11/4	64	14	4	140	31	125	127	M6x17	M25x1.5	M16x1.5	32	167	M6x15
EHS2-329	3~	368	395	39	114	328	363	361	185	205	128	152	265	68	148	G11/4	64	14	5	140	31	137	138	M6x17	M25x1.5	M16x1.5	32	192	M6x15
EHS2-339	3~	368	395	39	114	328	363	361	185	205	128	152	265	68	148	G11/4	64	14	5	140	31	137	138	M6x17	M25x1.5	M16x1.5	32	192	M6x15
EHS2-349	3~	418	455	39	127	371	406	364	129	235	111	105	271	72	172	G11/4	64	14	4	140	31	153	155	M6x17	M25x1.5	M16x1.5	32	228	M6x15
EHS2-359	3~	418	455	39	127	371	406	390	211	235	111	105	271	72	172	G11/4	64	14	4	140	31	153	155	M6x17	M25x1.5	M16x1.5	32	228	M6x15

EHS2(双级 / 三级) 气环真空泵型号及性能参数表 (IP55 50/60HZ)

EHS2/3AC (Double / three impeller) Gas ring vacuum pump models and the performance parameters table(IP55 50/60HZ)

型号 (EHS2 3AC) Model	单级	频率 frequency HZ	功率 power KW	马达额定参数		最大 排吸流量 Max airflow m³/h	额定 真空压力 rated Vacuum mbar	额定 压缩压力 rated compress mbar	噪音 noises db(A)	重量 weight Kg
	双级 double three			电压 voltage V	电流 current A					
EHS2-2301	双	50	0.85	200-240Δ/345-415Y	4Δ/2.3Y	47	-370	490	58	24
		60	0.95	220-275Δ/380-480Y	4Δ/2.3Y	60	-440	480	62	
EHS2-2302	双	50	1.6	200-240Δ/345-415Y	7.5Δ/4.3Y	47	-370	650	58	28
		60	2.05	220-275Δ/380-480Y	7.6Δ/4.4Y	60	-500	740	62	
EHS2-2303	双	50	1.1	200-240Δ/345-415Y	5.4Δ/3.1Y	65	-400	480	59	29
		60	1.3	220-275Δ/380-480Y	5.4Δ/3.1Y	76	-480	480	63	
EHS2-2304	双	50	1.6	200-240Δ/345-415Y	7.5Δ/4.3Y	65	-440	540	59	30
		60	2.05	220-275Δ/380-480Y	7.5Δ/4.3Y	76	-560	600	63	
EHS2-3310	双	50	1.6	200-240Δ/345-415Y	7.5Δ/4.3Y	87	-480	450	61	33
		60	2.05	220-275Δ/380-480Y	7.6Δ/4.4Y	105	-430	410	66	
EHS2-3311	双	50	3.3	200-240Δ/345-415Y	13Δ/7.5Y	87	-500	750	61	39
		60	3.8	220-275Δ/380-480Y	13.8Δ/8Y	105	-510	850	66	
EHS2-2312	双	50	2.2	200-240Δ/345-415Y	11.4Δ/6.6Y	120	-470	460	64	40
		60	2.55	220-275Δ/380-480Y	11.2Δ/6.5Y	145	-500	450	70	
EHS2-4330	双	50	4	345-415Δ	9.5Δ	120	-500	820	65	51
		60	4.6	380-480Δ	10Δ	145	-530	810	71	
EHS2-5310	双	50	3.3	200-240Δ/345-415Y	13Δ/7.5Y	165	-460	500	67	48
		60	3.8	220-275Δ/380-480Y	14.2Δ/8.2Y	195	-480	420	71	
EHS2-6310	双	50	5.5	345-415Δ	12Δ	165	-460	740	68	65
		60	6.6	380-480Δ	11.5Δ	195	-480	840	72	
EHS2-7310	双	50	7.5	345-415Δ	16Δ	170	-730	1040	72	86
		60	8.6	380-480Δ	16Δ	200	-700	1040	76	

EHS2 双级、三级 真空压缩选型曲线 3AC / Vacuum compression type curve

Vacuum Selection diagram 50 Hz—真空选型图表 50 Hz

Compressor Celetion Diagram 50 Hz—压缩选型图表 50 Hz

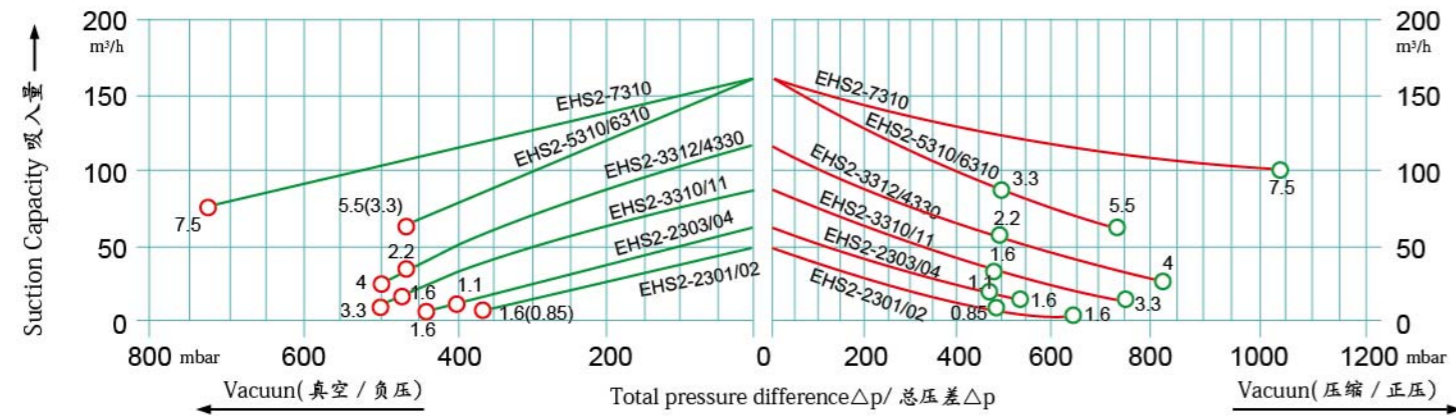

Vacuum Selection diagram 60 Hz—真空选型图表 60 Hz

Compressor Celetion Diagram 60 Hz—压缩选型图表 60 Hz

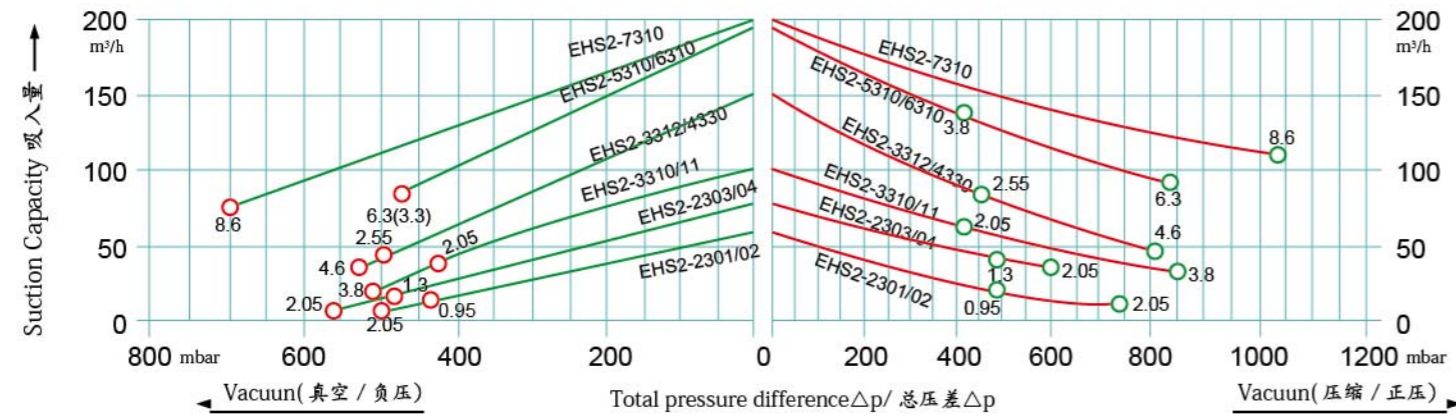

EHS2 双级 安装尺寸 Two stage mounting dimensions

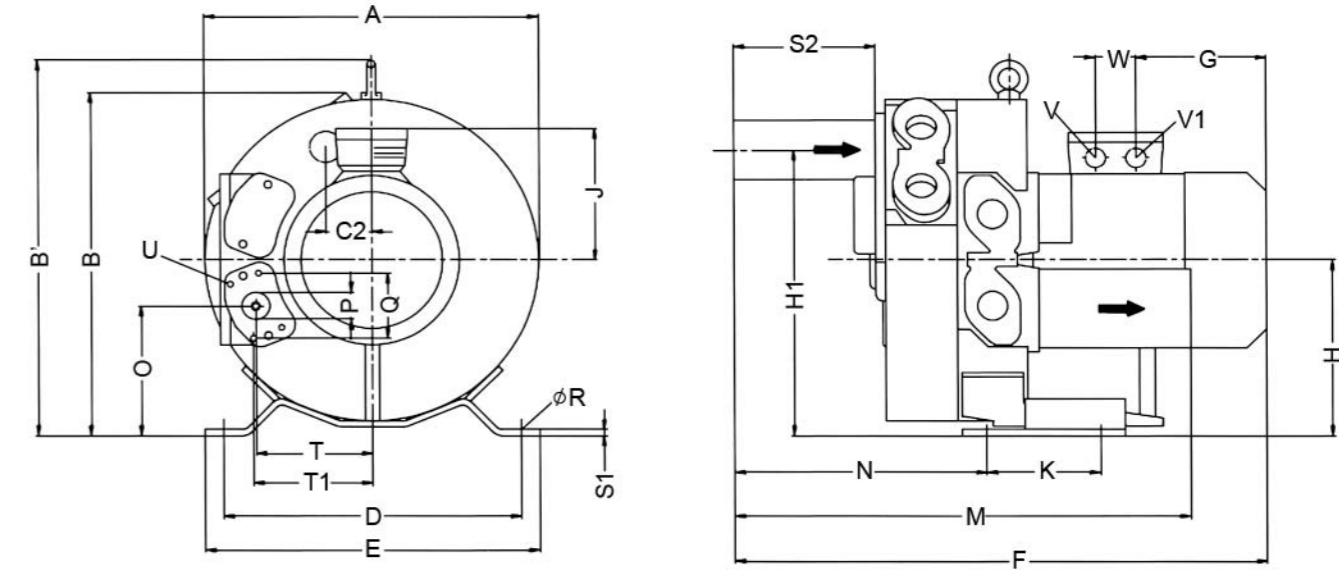

型号 Type	相位	A	B	B'	C2	D	E	F	G	H	H1	J	K	M	N	O	P	Q	R	S1	S2	S3	T	T1	U	V	V1	W
EHS2-2301	3~	313	326	359	43	260	298	525	185	167	272	128	105	426	241	123	G11/4	64	14	4	140	31	105	107	M6x17	M25x1.5	M16x1.5	32
EHS2-2302	3~	313	326	359	43	260	298	525	185	167	272	128	105	426	241	123	G11/4	64	14	4	140	31	105	107	M6x17	M25x1.5	M16x1.5	32
EHS2-2303	3~	331	345	380	47	290	325	390	153	177	291	120	105	431	243	130	G11/4	64	14	4	140	31	114	116	M6x17	M25x1.5	M16x1.5	32
EHS2-2304	3~	331	345	380	47	290	325	421	185	177	291	128	105	431	243	130	G11/4	64	14	4	140	31	114	116	M6x17	M25x1.5	M16x1.5	32
EHS2-3310	3~	363	377	414	52	315	350	529	180	195	319	128	130	436	243	143	G11/4	64	14	4	140	31	125	127	M6x17	M25x1.5	M16x1.5	32
EHS2-3311	3~	363	377	414	52	315	350	554	211	195	319	128	130	436	243	143	G11/4	64	14	4	140	31	125	127	M6x17	M25x1.5	M16x1.5	32
EHS2-2312	3~	387	402	435	57	328	363	549	185	206	343	128	152	453	256	148	G11/4	64	14	5	140	31	137	138	M6x17	M25x1.5	M16x1.5	42
EHS2-4330	3~	387	402	435	57	328	363	603	211	206	343	148	152	453	256	148	G11/4	64	14	5	140	31	137	138	M6x17	2xM32x1.5	M16x1.5	32
EHS2-5310	3~	442	457	495	63	372	406	578	211	236	389	128	152	458	259	173	G11/4	64	14	5	140	31	153	155	M6x17	M25x1.5	M16x1.5	42
EHS2-6310	3~	442	457	495	63	372	406	643	248	236	389	148	152	458	259	173	G11/4	64	14	5	140	31	153	155	M6x17	2xM32x1.5	M16x1.5	42

EHS2 三级 安装尺寸

Three stage mounting dimensions

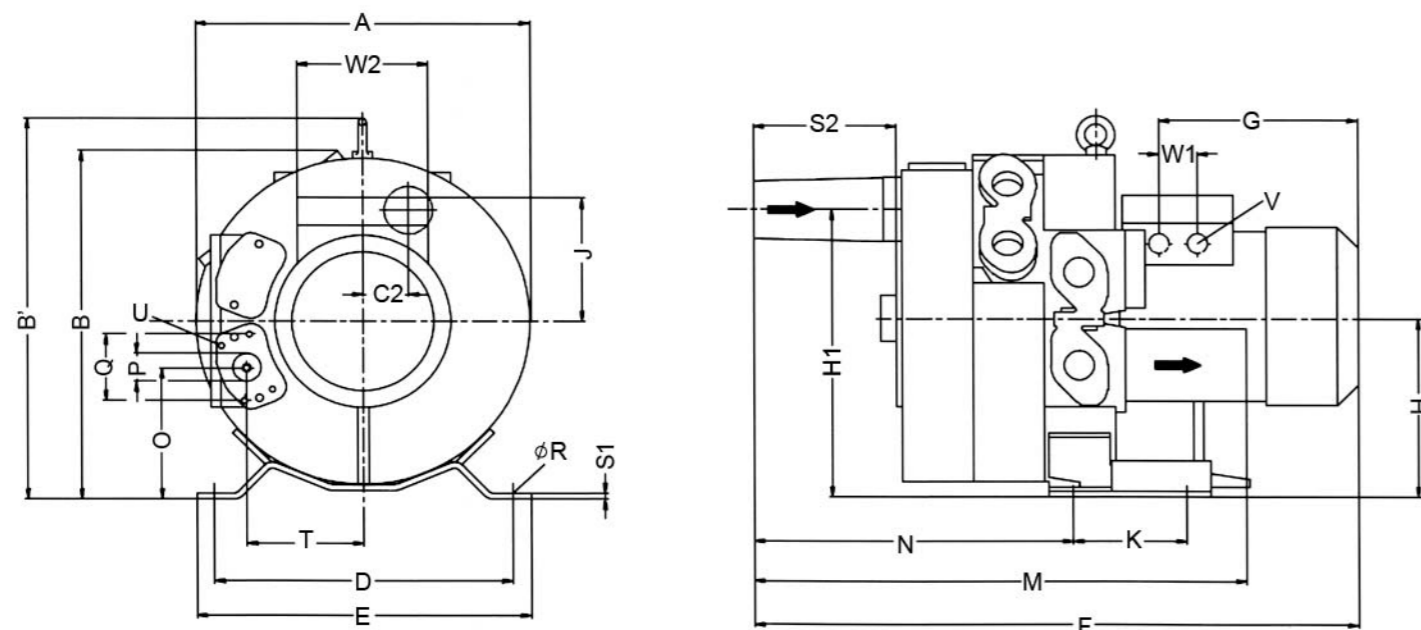

型号 Type	相位	A	B	B'	C2	D	E	F	G	H	H1	K	M	N	O	P	Q	φR	S1	S2	T	U	V	W1	W2
EHS2-7310	3~	442	402	492	63	371	406	717	274	236	389	152	539	336	172	G1 1/4	64	14	5	146	153	M6x17	M32x1.5	42	120

生產環境

全新模式，以智造占得时代先机

在互聯網+的時代背景下，率先啓動工業 4.0 戰略，引進先進生產設備、專業化技術團隊和高效化管理團隊，逐步對企業進行智能化、工業化、信息化相結合的改進升級，最終完成制造轉型升級，提升品牌根本創新力和競爭力。

A brand new mode: to take the lead with Chi-made products

In the Internet + background, takes the lead in carrying out the industry 4.0 strategy. We introduced advanced production equipment, specialized technical team and efficient management team. Thus, we gradually performed the intelligent, industrial and information upgrading, and finally realized manufacturing transformation and upgrading, which enhances our innovation ability and competitiveness.

